

# Paramount

## WALL MOUNTED STATIONARY INFRARED PATIO HEATER

Item # : LIP-15-TGG-WM-OP

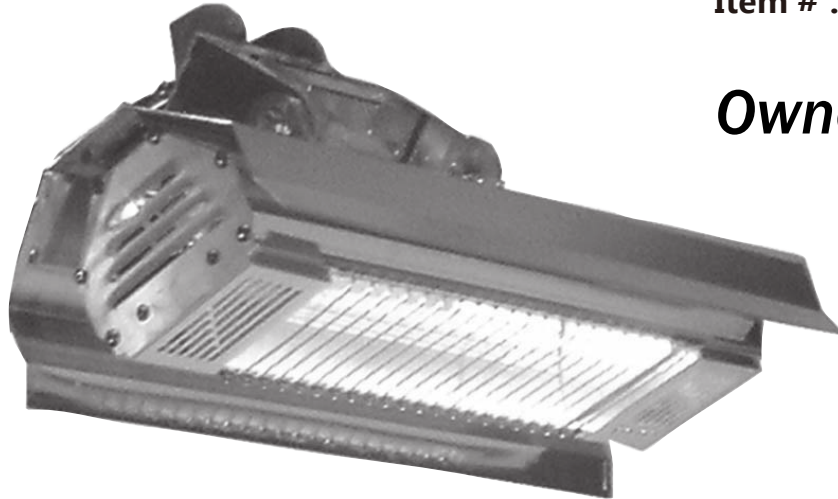

### Owner's Manual

**Recommended Primarily  
For Sheltered EXTERNAL Use  
Do NOT expose to rain or moisture**

#### ***READ & SAVE These Instructions***

***Carefully read and review before attempting to assemble,  
tall, operate or maintain this product. Observe all safety  
instructions and information. FAILURE TO FOLLOW  
WARNINGS & OPERATIONAL INSTRUCTIONS CONTAINED  
IN THIS MANUAL CAN RESULT IN  
SEVERE PROPERTY DAMAGE AND/OR PERSONAL INJURY.***

Do not expose to rain, moisture or flammable materials

**\*\*\*\*For Residential Use Only \*\*\*\***

**\*\*\* Important Notice \*\*\***

For customer service, parts  
or warranty issues:  
e-mail: [customercare@jrhome.com](mailto:customercare@jrhome.com)

**SAVE THESE INSTRUCTIONS !!**



J&R HOME PRODUCTS LTD.  
PITT MEADOWS B.C.  
CANADA



**\*\*\* Important Notice \*\*\***

**Do not return to place of purchase!!**

Please contact our Toll Free Hotline:

1.800.561.5550

for customer service & warranty issues

e-mail: [customer care@jrhome.com](mailto:customer care@jrhome.com)



*Paramount*

## Safety Guidelines

Read this manual carefully for guidance on the assembly and use of this product.

### DANGER

Indicates a potentially hazardous situation which, if not avoided, WILL result in serious injury or death.

### WARNING

Indicates a potentially hazardous situation, if not avoided, COULD result in serious injury or death.

### CAUTION

Indicates a potentially hazardous situation which, if not avoided, MAY cause moderate injury or damage to the equipment.

### NOTICE:

Indicated important information that if not followed, may cause damage to the equipment.

### DANGER

1



**Risk of Fire.** There is always a risk of fire when working with a heater. Keep heater away from flammable liquids and materials.



2. **Risk of Fire.** Follow instructions above and also for further prevention keep this unit at least 3 feet (.9m) away from everything.



3. **Hot or Burn Hazard.** This unit may be extremely hot while in use. Careful when handling especially around the head of the unit.



4. **Electrical Hazard.** Disconnect from electrical outlet before working on the unit to avoid chance of electrical shock.



5. **Electric Shock.** Do not use near water. Do not use if cord has been damaged.

### CAUTION

- Improper treatment of the heater can damage it and also shorten its life span.
- To prevent electrical shock, ensure electrical plug is properly inserted into the electrical outlet.
- Unit is hot when operating. Keep at least 3' away from everything. Do not place any objects such as furniture, papers, clothing or curtains closer than 3' to the front and sides of the heater

**\*\*\* Important Notice \*\*\***

**Do not return to place of purchase!!**

Please contact our Toll Free Hotline:

**1.800.561.5550**

for customer service & warranty issues

e-mail: [customer@jrhome.com](mailto:customer@jrhome.com)

**Recommended Primarily For**

**Sheltered EXTERNAL use**

**Do NOT expose to**

**rain or moisture**

*Paramount*

# Product Components & Parts List

***This appliance MUST be grounded.***

- \* When using outdoors, we recommend using a certified GFI (Ground Fault Interrupt) outlet to protect against electrical shock.
- \* Ensure that the heater mounting bracket is SECURELY fastened to the wall, patio overhang or house eave.
- \* Route electrical cable AWAY from main body of heater which gets very hot.
- \* Do NOT cover or obstruct the main body of the heater during use.
- \* All Installations must be in accordance with I.E.E. safety regulations or equivalent. If you are unsure, consult an electrical service professional.
- \* Avoid the use of an extension cord with this appliance.
- \* Do not place any objects such as furniture, papers, clothing or curtains closer than 3 ft to the front and sides of the heater.



NOTE: your IR Heater main body, electrical components & bracket are fully factory assembled. Do NOT attempt to service or disassemble without proper instructions.

## PARTS LIST

- 1 - IR Head Unit w/ Protective Aluminum Shield
  - Pre-installed wall mount component
  - Preassembled aluminum main heating unit w/1500W quartz halogen lamp, swivel bracket & 12 ft., 16/3 grounded electrical cord.
- 2 - Wall Mounting Bracket
- 3 - Hardware - 4 threaded bolts/screws, phillips pan head, 4 wall anchors, 1 short set screw.

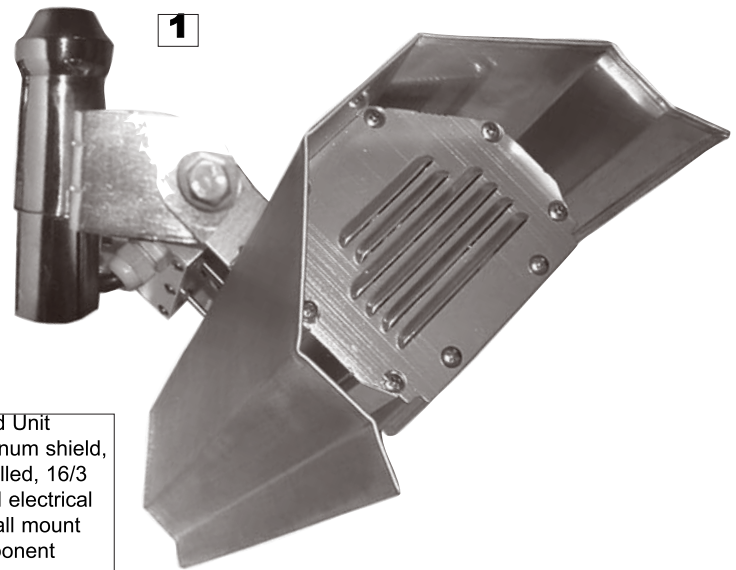

Head Unit  
With aluminum shield,  
pre-installed, 16/3  
grounded electrical  
cord, wall mount  
component



**2**  
Wall  
Mounting  
Bracket

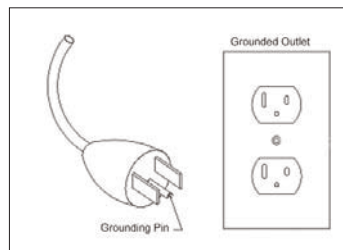



**\*\*\* Important Notice \*\*\***

**Do not return to place of purchase!!**

Please contact our Toll Free Hotline:

**1.800.561.5550**

for customer service & warranty issues

e-mail: [customercare@jrhome.com](mailto:customercare@jrhome.com)



*Paramount*

## Important Instructions

1. Read all instructions before using this heater.
2. This heater will get very hot while in use. To avoid burning, do not let bare skin touch hot surfaces. If provided, use handles when moving this heater. Keep flammable materials, such as furniture, pillows, bedding, papers cloths, and curtains at least 3 feet (0.9m) from the heater.
3. DO NOT LEAVE heater unattended. Extreme caution is necessary when any heater is used by, or near, children or disabled persons, and whenever the heater is left operating and unattended
4. Always unplug heater when not in use.
5. Do not operate any heater with a damaged cord or plug, if the heater malfunctions, or has been dropped or damaged in any manner. Return heater to authorized service facility for repairs.
6. Can be used indoors or outdoors, operate 3 feet (0.9m) from people or objects.
7. Never operate heater near water or where it can be knocked over.
8. Do not run cord under carpeting. Do not cover cord with throw rugs, runners, or similar coverings. Arrange cord away from traffic area and where it will not be tripped over.
9. To disconnect heater, remove plug from electrical outlet.
10. Connect to properly grounded outlets only.
11. Do not insert or allow foreign objects to enter ventilation or exhaust opening; doing so may cause an electrical shock or fire, or may damage the heater.
12. To prevent a possible fire, do not block air intakes or exhaust in any manner. Do not use on soft surfaces, like a bed, where openings may become blocked.
13. A heater has hot and sparking parts inside. Do not use it in areas where gasoline, paint, or flammable liquids are used or stored.
14. Use this heater only as described in this manual. Any other use not recommended by the manufacturer may cause fire, electrical shock, or injury to persons.
15. Avoid the use of an extension cord because the extension cord may overheat and cause a risk of fire. However, if you have to use an extension cord, use either a 12 or 14 gauge wire which is rated not less then 1900 watts. The recommended length for a 14 gauge is 0-50 feet, but if need be long use a 12 gauge no longer then 100 feet.
16. SAVE THESE INSTRUCTIONS for future reference.



**\*\*\* Important Notice \*\*\***

**Do not return to place of purchase!!**

Please contact our Toll Free Hotline:  
**1.800.561.5550**

for customer service & warranty issues  
e-mail: [customer care@jrhome.com](mailto:customer care@jrhome.com)

# Assembly & Installation

# Paramount

## Step 1

Be sure to read and familiarize yourself with the overall assembly and installation instructions in this manual before beginning. It may be helpful to have someone assist you with the installation. **This unit is primarily designed for outdoor applications.**

**Tools Required:** #2 or #3 Phillips Screwdriver (or standard slotted screwdriver), adjustable wrench, pencil, 5/16" drill bit & drill and a ladder.

## Step 2

Find a suitable location to mount the heater unit, **be sure to comply with ALL minimum required distances and clearance specifications. See illustration below, fig. 3.**

\* Do not place any objects such as furniture, papers, clothing or curtains closer than 3 ft to the front and sides of the heater.

- Position mounting bracket flush against the wall where you want to position the IR unit. Make sure the bracket is level and mark the centers of the holes with a pencil. Note the proper upright orientation of the bracket, see fig. 1.
  - Drill 4 pilot holes approx. 1 5/8" deep. For mounting on stucco walls and/or locations where there is not a wood stud, be sure to use appropriate wall anchors to properly secure mounting bracket to wall.
- Attach wall bracket using the 4 screws included (and wall anchors if applicable). Apply all 4 screws loosely at first, check that the bracket is level and then tighten securely.

## Step 3

- \* Insert wall mount assembly from head unit into wall mount bracket. See fig. 2.
  - Note orientation of bracket and head unit.
- \* Align and apply small set screw to bottom of wall bracket and thru the wall mount of the head unit to lock head unit into place. Tighten securely.

**\*\*\* IMPORTANT NOTE: be sure to route and keep the electrical cord AWAY from the main body of the heater unit. \*\*\***

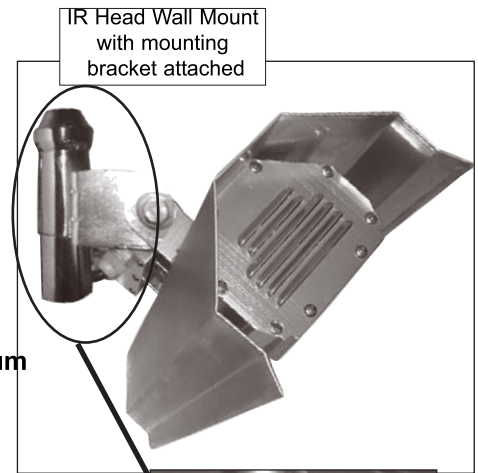

**Fig. 1**

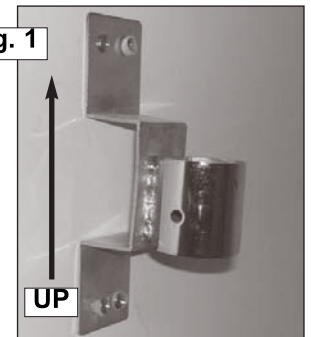

**Fig. 2**

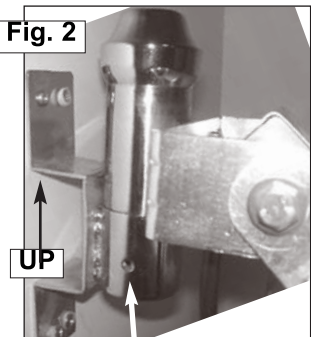

**Apply two threaded bolts and lock washers to lock the position of the head unit.**

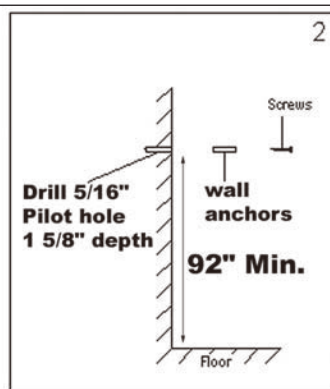
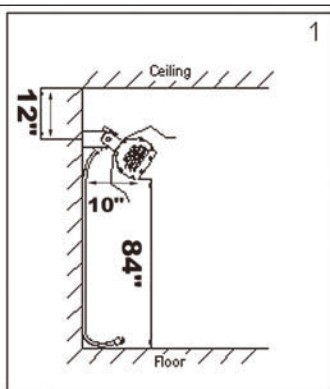

**Fig. 3**

**Min. Clearances:**

- \* 83" head unit height
- \* 10" from mounting wall
- \* 12" from surfaces above the heater head unit
- \* 36" from sides and front of head unit
- \* 45-55 degree angle of operational spread

Heater MUST always face the floor

Route power cord below and away from head unit as show in box 5.

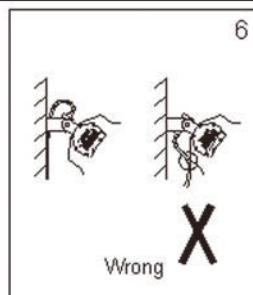
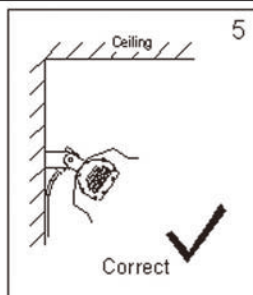
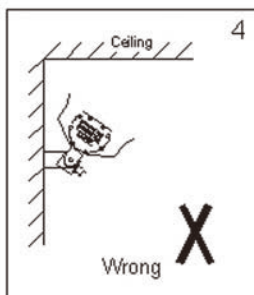
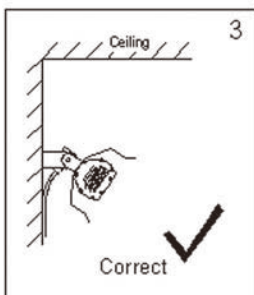

**\*\*\* Important Notice \*\*\***

**Do not return to place of purchase!!**

Please contact our Toll Free Hotline:  
**1.800.561.5550**

for customer service & warranty issues  
e-mail: [customer care@jrhome.com](mailto:customer care@jrhome.com)

# Operating Instructions

# Paramount



***This appliance MUST be grounded.***

- \* When using outdoors, we recommend using a certified GFI (Ground Fault Interrupt) outlet to protect against electrical shock.
- \* Ensure that the heater mounting bracket is **SECURELY** fastened to the wall, patio overhang or house eave.
- \* Route electrical cable **AWAY** from main body of heater which gets very hot.
- \* Do **NOT** cover or obstruct the main body of the heater during use.
- \* All Installations must be in accordance with I.E.E. safety regulations or equivalent. If you are unsure, consult an electrical service professional.
- \* Avoid the use of an extension cord with this appliance. If one is used, it **MUST be at least a 14/3 wire, grounded cord, 50ft max. length.**
  
- \* **Do not place any objects such as furniture, papers, clothing or curtains closer than 3 ft to the front and sides of the heater.**

NOTE: your IR Heater main body, electrical components & bracket comes fully factory assembled. Do **NOT** attempt repair or disassembly, contact our toll free customer service hotline for assistance.



**For optimal performance and safety concerns, we *HIGHLY RECOMMEND* that the Infrared Heater Head be operated at a min. of 84" ht. with a 45-55 degree angle of operational spread.**

**To Adjust The IR Head Unit:**

Swivel head unit up or down to desired position. The head unit must be at a 45-55 degree angle for optimal operation and output. There should only be a moderate amount of tension to maintain the swivel bracket. If it becomes too loose, tighten hex nuts and bolts at swivel points on head unit bracket.

**Note: Be sure electrical cord is routed and positioned away from head unit.**

## Step 1

Before turning on your Infrared Heating System, adjust the head unit angle as desired. Do **NOT** touch the head unit during operation or for 30 minutes **AFTER** shut off.

**The head units GETS VERY HOT!**

Refer to coverage area in **Fig. 7** for best positioning location and heat spread/coverage.

## Step 2

The infrared electric heating system comes equipped with a heavy duty, 16/3 gauge wire and grounded plug. This appliance must be used with an outlet that has been installed and grounded in accordance with all local codes and ordinances. Make sure that the heater is connected to an outlet having the same configuration as the plug shown in **Fig. 8**. Do **NOT** use an adapter with this product. Check with a licensed electrician if the grounding instructions are not understood completely or if the wall outlet does not match the plug.

## Step 3

**Always UNPLUG unit when not in use!**

Your Paramount infrared electric heating system is ready to enjoy. Plug the appliance in and beginning enjoying the warmth!

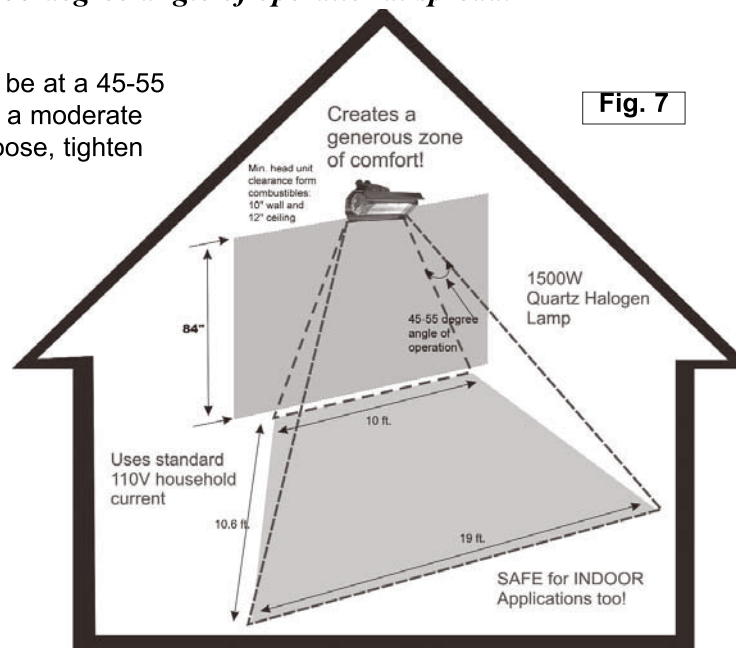

**Fig. 7**

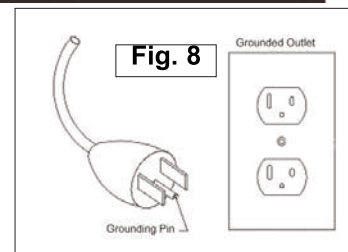

**Fig. 8**



**\*\*\* Important Notice \*\*\***

**Do not return to place of purchase!!**

Please contact our Toll Free Hotline:  
**1.800.561.5550**  
for customer service & warranty issues  
e-mail: [customercare@jrhome.com](mailto:customercare@jrhome.com)

# MAINTENANCE & STORAGE

## Specifications

|                          |                 |
|--------------------------|-----------------|
| Model:                   | LIP15TGG-WM-OP  |
| Voltage:                 | 120 volts       |
| Amps:                    | 12.5 amps       |
| Wattage:                 | 1500 watts      |
| Lamp Type:               | Quartz Halogen  |
| Min. Operational Height: | 84" (7 ft.)     |
| Weight:                  | 5.5 lbs.        |
| Head Unit Dimensions:    | 4.5" x 7" x 22" |

## Storage

### **Always UNPLUG unit when not in use!**

- \* The IR Head unit can be left outside during the season as long as it is mounted under a covered, protected location.
  - During expected moderate weather conditions, we recommend wrapping the head unit with a poly bag and tape or a bungee cord. For extreme weather conditions, it is recommended that you remove the unit from the wall bracket and store in a safe, dry indoor location.
- \* When not in use for extended periods of time, the IR Head Unit can be easily removed from the wall mounting bracket for storage indoors. Refer to step 3, page 5 of this manual.
  - **The halogen lamp is fragile, be careful not to hit or jar the head unit.**
  - Store in a dry location placing the head unit on a soft cushioned surface.
  - Make sure the electrical cord is properly coiled and out of the way.

## Maintenance

**Your infrared heating system is virtually maintenance free! A few minutes to wipe down exposed surfaces is all it takes.**

- \* **Head Unit & Aluminum Shield** - Use any non-abrasive cleaner and soft cloth to wipe off debris and dirt from the exposed surfaces of the aluminum shield and outer body of the head unit and outer grill. NEVER spray any liquids or cleaners into the housing area where the halogen lamp is located. **Do not try to disassemble or clean the inner cavity where the halogen lamp is located.**

Note: For any maintenance on the head unit, please call the toll free customer service hotline.

- \* For halogen lamp replacement instructions, refer to information on page 8 of this manual.





**\*\*\* Important Notice \*\*\***

**Do not return to place of purchase!!**

Please contact our Toll Free Hotline:

**1.800.561.5550**

for customer service & warranty issues

e-mail: [customer@jrhome.com](mailto:customer@jrhome.com)

## Halogen Lamp Replacement

**NOTE: do NOT touch the new halogen lamp with your bare fingers. Oils from your hand could reduce the life of the lamp by causing a heat spot. Recommend using clean cotton or plastic gloves. A clean paper towel may also work.**



**Make sure heater is DISCONNECTED from electrical outlet BEFORE beginning**

### Quartz Halogen Lamp Replacement:

- \* Be sure unit is unplugged from wall outlet!
- \* Remove head unit assembly from wall mounting bracket (refer to step 3 from page 5)
- \* Remove 8 screws from each end of the head unit and pull off end plates (see #2)
  - Note the placement of the 2 small sheet metal screws on each end plate.
  - Also, note end plate side with beveled holes faces outward when re-assembled.
- \* Pull out & remove the left & right, front air vent panels and protective wire grill. (see #3)
  - Note position of end clips on vent panel. They must be aligned as close to end connectors of lamp tube as possible when re-assembled. Pull out and/or pushed into place.

**Do NOT allow any metal parts to touch the actual lamp tube when re-assembled.**

- \* Gently pull out entire old lamp assembly from the clips at the terminal connection ends. (see #4 & #5). Slide and lift the connection ends out from the friction clips by gently pushing apart the clips. Unscrew wire leads from terminal. Remove entire old lamp assembly.
- \* Using gloves, gently re-insert connection ends of the NEW lamp assembly into the friction clips (see #4). Pull apart the clips slightly and gently push the connectors into place. Do not allow the metal clips to touch the actual lamp tube. The clips should be about at the center point of the end connectors.
- \* Re-install safety grill (fits along grooves in housing body). Then, re-insert vent panels by gently pushing the end clips into housing body, align clip ends close to lamp end connectors and push into place. Now re-attach end plates, make sure side with beveled holes faces out.



**Use ONLY approved, original equipment replacement quartz halogen lamps to insure safe, proper and maximum output operation of your infrared heater!**

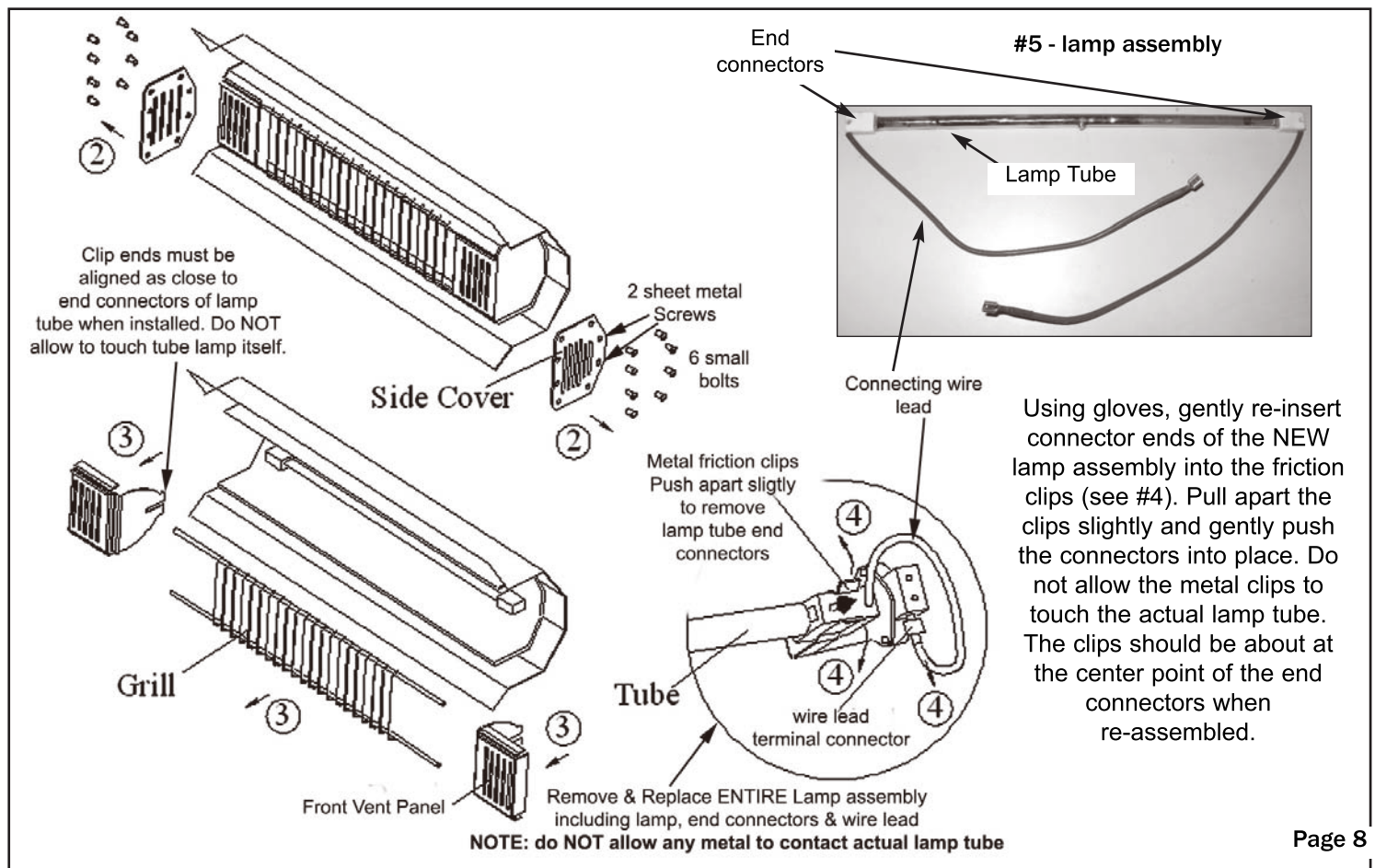

## ***Troubleshooting***

### **Problem**

Unit fails to turn on.

Head unit is loose or unsteady  
Head unit is hard to adjust

Smoke appears from head unit

Weak light output from halogen lamp

### **Solution**

Check electrical plug connection at wall outlet for complete, snug fit.  
Check GFI circuit, reset breaker if necessary  
Possibly connected to wall switch that is in off position  
Damaged halogen lamp, call customer service hotline

Tighten connecting bolts/nuts at swivel bracket  
Loosen connecting bolts/nuts at swivel bracket

Unplug IMMEDIATELY & call customer service hotline

Life span of lamp has been reached or damaged lamp  
Call customer service hotline for assistance.

# IMPORTANT

For questions, concerns or problems with our product please  
email our customer service department:

**customercare@jrhome.com**

DATED PROOF OF PURCHASE REQUIRED FOR WARRANTY SERVICE

## WARRANTY

This product is inspected, tested and carefully packaged to minimize the chance of damage during shipment. If a part (excluding light bulbs and fuses\*) within one year from the date of purchase proves to be defective in material or fabrication under normal use, the part will be repaired or replaced. The Company's obligation under the warranty is to replace or repair defective parts at our discretion. Any expenses or damage resulting from the installation, removal or transportation of the product will be the responsibility of the owner and are not covered by this warranty. The owner assumes all other risks arising from the use or misuse of the product. The warranty will be void if the product damage or failure is deemed by the Company to be caused by accident, alteration, misuse, abuse, incorrect installation or removal, or connection to an incorrect power source by the owner. The Company neither assumes, nor authorizes any person or entity to assume for it any obligation or liability associated with its products. Light bulbs and fuses are not covered under this warranty. If you have any questions regarding the warranty or service, please contact us at **customercare@jrhome.com**.

Customer Service:

JR Home Products

Unit 306 - 19100 Airport Way, Pitt Meadows, BC V3Y 0E2

Toll Free: 1-800-561-5550

E-mail: **customercare@jrhome.com**

**You MUST register your product to receive warranty service.**

**Registration can be completed online at [www.jrhome.com](http://www.jrhome.com) or by mailing this form.**

## Warranty Registration Information Form / Formulaire d'enregistrement de la garantie

Name / Nom: \_\_\_\_\_

Street / Adresse: \_\_\_\_\_

City / Ville: \_\_\_\_\_

Province / Province: \_\_\_\_\_

Postal Code / Code postal: \_\_\_\_\_

Daytime Phone # / No téléphone jour: \_\_\_\_\_

Evening Phone # / No téléphone soir: \_\_\_\_\_

E-Mail Address / Courriel: \_\_\_\_\_

Product/Produit: \_\_\_\_\_

Place of Purchase / Lieu de l'achat: \_\_\_\_\_

Date of Purchase / Date de l'achat: \_\_\_\_\_

Model # / No de modèle: \_\_\_\_\_

Serial # / Numéro de série: \_\_\_\_\_

You MUST register your product to receive warranty service.

For warranty service, contact J&R Home Products at the address, phone numbers listed below within 30 days of purchase. Be sure to have your sales receipt and original date of purchase. All warranty service will be coordinated by J&R Home Products service center.

Vous DEVEZ enregistrer votre produit pour vous prévaloir de la garantie.

Afin de faire valoir la garantie, communiquez avec J&R Home Products à l'adresse et aux numéros indiqués ci-dessous dans les 30 jours suivant la date d'achat. Ayez en main votre reçu et la date d'achat. Toutes les demandes liées aux garanties seront traitées par le centre de service de J&R Home Products.