



Our Commitment to Your Family

A Beachcomber Hot Tub is an investment in you and your family. Since 1978, our extended family of stores around the world have been helping people just like you to make a solid, informed decision about buying a hot tub. We have always believed in giving the information and education needed to make that important decision. We know that the sale really begins after you have your Beachcomber in your home.

Our desire for you is to have the best experience possible with your new Beachcomber Hot Tub, that's why our stores are equipped to help you with any additional needs you may have. From our family to yours, thank you for putting your trust in us and our products. We are pleased that you have chosen Beachcomber, and hope you recommend us to your friends and relatives.



Keith and Judy Scott
Founders of Beachcomber Hot Tubs

Stock Code: 2092020
Fifth Printing: November 2012

Beachcomber Hot Tub Owner's Guide



beachcomber
HOT TUBS

beachcomber. the green hot tub company™

beachcomber. the green hot tub company™

Ask for Beachcomber Water Care Products at Participating Beachcomber Stores

BEACHCOMBER'S RECOMMENDED PARAMETERS FOR COMFORTABLE, BALANCED HOT TUB WATER

Your store may recommend slightly different levels depending on your local source water. Please see your store for more information by taking a water sample in to be analyzed. Maintaining balanced water is very important to protect your hot tub and its equipment. Failure to maintain proper water balance could damage your hot tub and equipment, which is not covered by your guarantee. Your Beachcomber store can provide you with free computer water analysis, treatment solutions and home testing products.

SANITIZER / DISINFECTANT IDEAL LEVEL: 3 - 5 PPM

Always maintain an adequate sanitizer level. Failure to do so will result in cloudy water, odor and skin or respiratory problems. The ideal range is 3 - 5 ppm. Check daily with test strips or a test kit available from your Beachcomber store.

- Do not mix products together.
- Add chemical to water, not water to chemicals.
- Do not allow liquids to freeze.
- Keep out of reach of children.
- Add one product at a time directly to hot tub water.
- Store chemicals in a cool, dry place.

PH IDEAL LEVEL: 7.2 - 7.8

The pH level is the measure of the acidity or alkalinity of water, 7.2 being neutral. Water that is too alkaline (over 7.8) can cause calcium scale to develop; too acidic (below 7.2) can cause corrosion. Either condition can damage your hot tub and create unpleasant bathing conditions. Test the pH every week or more often if possible. Use Beachcomber's **Resist** to raise Alkalinity, thereby raising the pH; or Beachcomber's **pH Plus** or **pH Minus** can also adjust pH.

TOTAL ALKALINITY IDEAL LEVEL: 100 - 120 ppm

Total Alkalinity in balance stabilizes the pH level, prevents scaling and ensures that your sanitizer works at peak efficiency. Use Beachcomber's **Resist** to increase the level or **pH Minus** to lower the level. Adjust at initial fill or when topping up.

CALCIUM HARDNESS IDEAL LEVEL: 150 - 200 ppm

High Calcium can cause cloudy water (calcium in solution) or scaling on the hot tub surface and heating element. Too low a level can lead to excess foaming in the water. Use Beachcomber's **Protect** to increase the level; use fresh water dilution to lower the level. Adjust at initial fill and when topping up.

TOTAL DISSOLVED SOLIDS IDEAL LEVEL: NOT MORE THAN 1500 ppm

Total Dissolved Solids (TDS) is the measure of solids in the water. After 1500 ppm has accumulated, it is time to drain the hot tub. Have your Beachcomber store measure this level for you. A basic rule of thumb is 3 months under normal usage conditions. Or, when water becomes listless, cloudy or foamy after that period of time, it is time to drain the hot tub. Water with a high TDS level responds poorly to water care product treatment and requires water replacement.

IMPORTANT WATER CONDITIONERS THAT IMPROVE PERFORMANCE

1. Metal and mineral sequestering product must be added to keep any metals or minerals in the water in solution. Use **Eliminate #1** at initial fill.
2. Scale inhibitor prevents calcium buildup forming on surfaces in the hot tub. Use **Eliminate Plus #2** at initial fill and weekly.
3. Water Clarifier agglomerates tiny particles in the water, to be picked up by the Microfilter. It also provides lubrication to seals. Use **Pure Blue** at initial fill and weekly.
4. Enzymes, a completely natural compound, eliminates scum at the water line, assists the filter, and removes odor and organic contaminants. Use **Purezyme #3** at initial fill and weekly.

Beachcomber offers a full line of recommended water care products to get the most from your Beachcomber Hot Tub. Since 1978, we have been providing Beachcomber owners with custom formulated products to meet the needs of your hot tub. Always follow the directions on product labels.

WARNING

DO NOT ENTER A HOT TUB WITHOUT ADEQUATE SANITIZATION / DISINFECTION.

WARNING

ALWAYS FOLLOW THE LABEL INSTRUCTIONS AND WARNINGS ON BEACHCOMBER WATER CARE CHEMICAL BOTTLES.

WARNING

DO NOT ALLOW CHILDREN TO USE A HOT TUB WITHOUT ADULT SUPERVISION. PREVENT UNAUTHORIZED CHILD ACCESS TO AVOID THE RISK OF DROWNING.

WARNING

WHEN SHOCK TREATING HOT TUB WATER, LEAVE THE COVER SLIGHTLY OPEN TO ALLOW VAPOR TO ESCAPE FOR 1 HOUR. HIGH LEVELS OF SANITIZER DAMAGES THE UNDERSIDE OF THE COVER, WHICH IS NOT COVERED BY YOUR COVER GUARANTEE.

Record Important details of your new Beachcomber Hot Tub

MODEL NUMBER: _____ DATE OF PURCHASE: _____

HOT TUB SERIAL NUMBER: _____ STORE NAME: _____

GUARANTEE NUMBER: _____ STORE PHONE: _____

Familiarize yourself with the components of your personal Beachcomber Hot Tub. Some of these features shown may be optional at extra cost and are shown here for the safety and convenience of our worldwide customers.

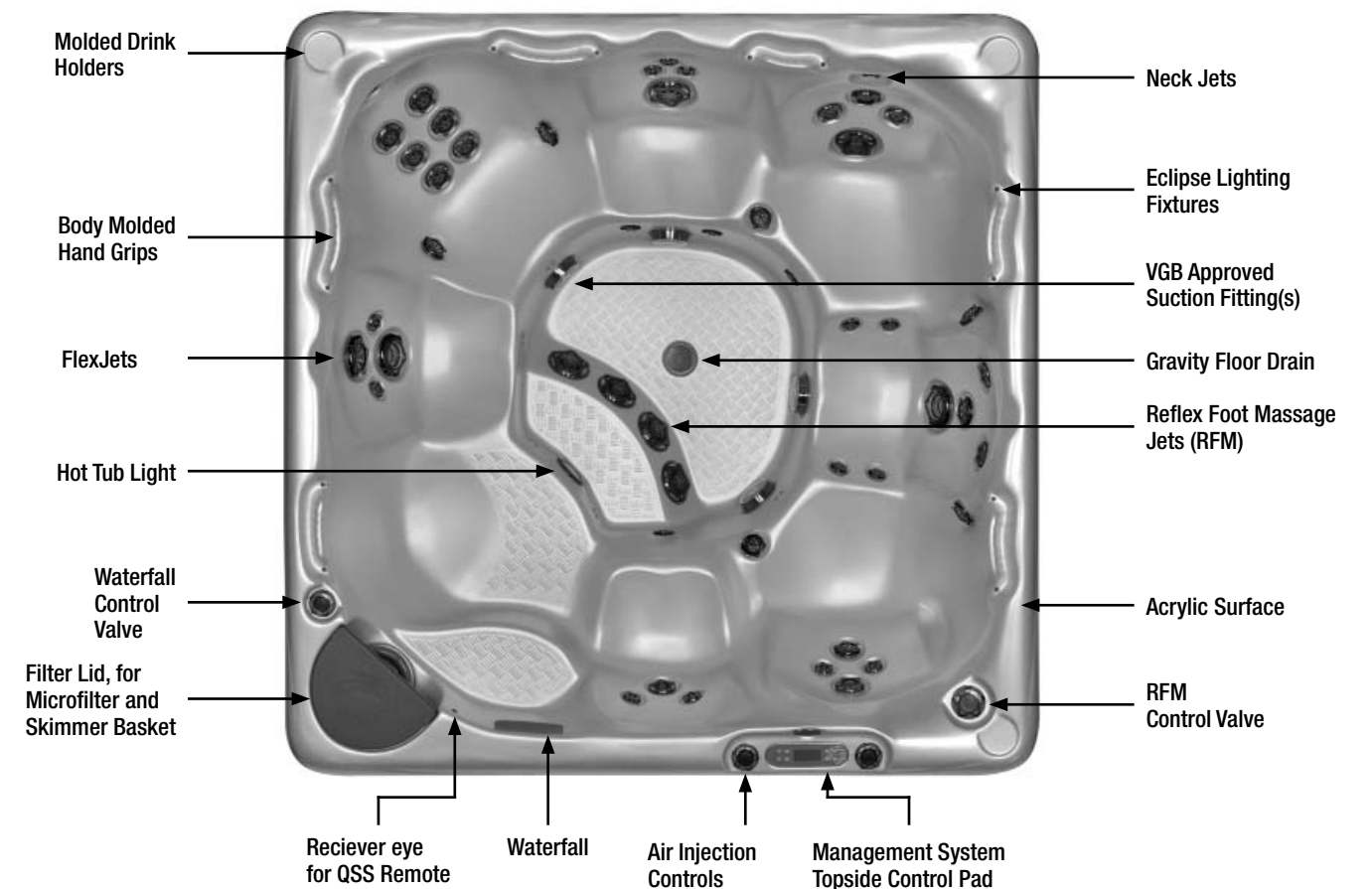



Important Safety Instructions

When using this electrical equipment, basic safety precautions must be followed, including the following:

A) READ AND FOLLOW ALL INSTRUCTIONS.

B) A green colored terminal, or terminal marked G, GR, Ground, Grounding or the international grounding symbol is located inside the supply terminal box or compartment. To reduce the risk of electric shock, this terminal must be connected to the grounding means provided in the electrical supply service panel with a continuous copper wire equivalent in size to the circuit conductors supplying this equipment.

C) At least two lugs marked "BONDING LUGS" are provided on the external surface or on the inside of the supply terminal box or compartment. To reduce the risk of electric shock, connect the local common bonding grid in the area of the hot tub or spa to these terminals with an insulated or bare copper conductor not smaller than No. 6 AWG.

D) All field installed metal components such as rails, ladders, drains, or other similar hardware within 3 meters / 9.84 feet of the spa or hot tub shall be bonded to the equipment grounding bus with copper conductors not smaller than No. 6 AWG.

E) **WARNING: WATER TEMPERATURE IN EXCESS OF 38° C / 100° F MAY BE INJURIOUS TO YOUR HEALTH.** Refer to the temperature adjustment instructions for your topside control panel type.

F) SAVE THESE INSTRUCTIONS.

CAUTION:

WIRING CONNECTED IN THIS BOX MUST BE RATED AT 300V.

There are no user serviceable parts within the management system. The high voltage can cause injury or death. The hot tub must be hooked up to a Ground Fault Circuit Interrupter (G.F.C.I.) by a licensed electrician. Use the test button on your G.F.C.I. monthly to ensure it is working properly.

Always make sure there is an adequate sanitizer level in your hot tub before entering. Failure to do so may cause skin irritations or illness. Use a test kit or test strips to check prior to entry.

CAUTION:

WATER TEMPERATURE MAY NEED TO BE DECREASED FOR CHILDREN OR THE ELDERLY.

Hot Tub Specifications and Details

MODEL	SEATING CAPACITY	WATER CAPACITY	DRY WEIGHT	FILLED WEIGHT
750	8 people plus one cooling seat	437 US gallons / 1654 litres	800 lbs / 363 kg	4446 lbs / 2017 kg
740	6 people plus one cooling seat	403 US gallons / 1525 litres	800 lbs / 363 kg	4162 lbs / 1888 kg
725	6 people plus one cooling seat	335 US gallons / 1268 litres	675 lbs / 306 kg	3470 lbs / 1574 kg
720	7 people plus two cooling seats	362 US gallons / 1370 litres	675 lbs / 306 kg	3695 lbs / 1676 kg
580	8 people plus one cooling seat	430 US gallons / 1628 litres	725 lbs / 329 kg	4312 lbs / 1956 kg
578	7 people plus one cooling seat	362 US gallons / 1370 litres	650 lbs / 295 kg	3670 lbs / 1665 kg
550	6 people plus two cooling seats	380 US gallons / 1438 litres	650 lbs / 295 kg	3820 lbs / 1733 kg
540	5 people plus one cooling seat	300 US gallons / 1136 litres	600 lbs / 272 kg	3103 lbs / 1408 kg
520	seating for 2 people	175 US gallons / 662 litres	425 lbs / 193 kg	1885 lbs / 855 kg
380	7 people plus one cooling seat	418 US gallons / 1582 litres	725 lbs / 329 kg	4212 lbs / 1911 kg
360	6 people plus one cooling seat	345 US gallons / 1306 litres	650 lbs / 295 kg	3528 lbs / 1601 kg
350	6 people plus one cooling seat	375 US gallons / 1419 litres	650 lbs / 295 kg	3778 lbs / 1714 kg
340	5 people plus two cooling seats	300 US gallons / 1136 litres	640 lbs / 290 kg	3143 lbs / 1426 kg
321	4 - 5 people plus one cooling seat	242 US gallons / 916 litres	425 lbs / 193 kg	2444 lbs / 1109 kg

Beachcomber Hot Tub Care and Maintenance Record

DATE	CLEAN THE MICROFILTER	SOAK THE MICROFILTER	DRAIN AND REFILL THE HOT TUB	CLEAN HEATSHEILD COVER	WATER SAMPLE TO LOCAL STORE
1-					
2-					
3-					
4-					
5-					
6-					
7-					
8-					
9-					
10-					
11-					
12-					

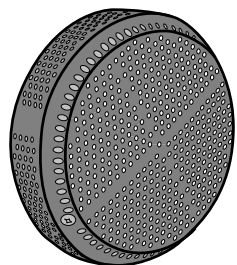

Beachcomber's Suction Fittings are factory installed, located in the hot tub footwell. They prevent hair or body entrapment. All Beachcomber Suctions are VGB approved.

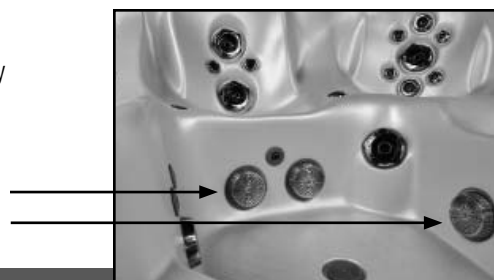

IMPORTANT INFORMATION FOR THE OPTIONAL QUINTESSENTIAL SURROUND SOUND SYSTEM

CAUTION – RISK OF ELECTRIC SHOCK. DO NOT LEAVE COMPARTMENT DOOR OPEN.

REPLACE COMPONENTS ONLY WITH IDENTICAL COMPONENTS AND DO NOT OPERATE THE AUDIO CONTROLS WHILE INSIDE THE HOT TUB.

Do not service this product yourself as opening or removing covers may expose you to dangerous voltage or other risk of injury. Refer all servicing to qualified personnel. Turn off power to the hot tub and seek assistance from qualified personnel if any of these conditions exist:

- power supply connections or cord is damaged;
- water entering the audio unit compartment;
- water entering any part of the hot tub equipment or management system;
- protective shield showing any sign of deterioration;
- or signs of damage or deterioration to your hot tub.

For operation instructions for your QSS console shown below, consult the separate Owner's Manual that you received with your Beachcomber Hot Tub.



Beachcomber's
Quintessential Surround
Sound System Console

WARNING

PREVENT ELECTROCUTION. DO NOT CONNECT ANY AUXILIARY COMPONENTS SUCH AS CABLE, ADDITIONAL SPEAKERS, HEADPHONES OR ADDITIONAL AUDIO/VIDEO COMPONENTS TO THE SYSTEM.

TAKE PART IN AN ONLINE SURVEY

Your Beachcomber Hot Tub purchase is very important to us. We would like to know about your buying experience and your level of satisfaction with us, our Beachcomber store and your new hot tub. Please take a few minutes to log on to our website to take a short questionnaire. Your feedback helps us improve our service to you and gives us valuable insight into your purchase experience. Log on to our website today.

Thank you for your time!

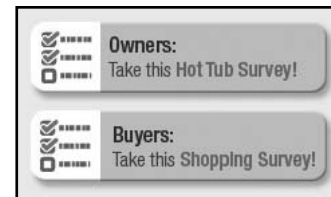

www.beachcomberhottubs.com

WARNING	
DURING PREGNANCY, SOAKING IN HOT TUB WATER MAY CAUSE DAMAGE TO THE FETUS. LIMIT USE TO 10 MINUTES AT A TIME.	
<p>PREVENT DROWNING</p> <p>SPA HEAT SPEEDS UP EFFECTS OF ALCOHOL, DRUGS, OR MEDICINE AND CAN CAUSE UNCONCIOUSNESS. IMMEDIATELY LEAVE SPA IF UNCOMFORTABLE OR SLEEPY.</p>	<p>PREVENT CHILD DROWNING</p> <p>WATER ATTRACTS CHILDREN ALWAYS ATTACH A SPA COVER AFTER EACH USE.</p>

WARNING

CHILDREN SHOULD NOT USE SPAS OR HOT TUBS WITHOUT ADULT SUPERVISION.

WARNING

DO NOT USE SPAS OR HOT TUBS UNLESS ALL SUCTION GUARDS ARE INSTALLED TO PREVENT BODY AND HAIR ENTRAPMENT.

WARNING

PEOPLE USING MEDICATIONS AND/OR HAVING AN ADVERSE MEDICAL HISTORY SHOULD CONSULT A PHYSICIAN BEFORE USING A SPA OR HOT TUB.

WARNING

PEOPLE WITH INFECTIOUS DISEASES SHOULD NOT USE A SPA OR HOT TUB.

WARNING

TO AVOID INJURY, EXERCISE CARE WHEN ENTERING OR EXITING THE SPA OR HOT TUB.

WARNING

DO NOT USE DRUGS OR ALCOHOL BEFORE OR DURING THE USE OF A SPA OR HOT TUB TO AVOID UNCONCIOUSNESS AND POSSIBLE DROWNING.

WARNING

PREGNANT OR POSSIBLY PREGNANT WOMEN SHOULD CONSULT A PHYSICIAN BEFORE USING A SPA OR HOT TUB.

HYPERTHERMIA

CAUTION: THE EQUIPMENT AND CONTROLS SHALL BE LOCATED NOT LESS THAN 3.5 ft OR 1m HORIZONTALLY FROM THE HOT TUB.

Hyperthermia occurs when the internal temperature of the body reaches a level of several degrees above normal body temperature of 98.6° F / 37° C. The symptoms of hyperthermia include drowsiness, lethargy and an increase of internal temperature of the body.

THE EFFECTS OF HYPERTHERMIA INCLUDE:

- unawareness of impending heat;
- failure to perceive heat;
- failure to recognize the need to exit the spa or hot tub;
- physical inability to exit the hot tub;
- fetal damage in pregnant women;
- unconsciousness and danger of drowning.

Recommended time in water at 100° F / 38° C is 15 minutes. Lower temperatures will permit longer bathing times. Always check the temperature of the water before entry with an accurate thermometer.

WARNING

THE USE OF ALCOHOL OR DRUGS CAN GREATLY INCREASE THE RISK OF FATAL HYPERTHERMIA IN HOT TUBS AND SPAS.

WARNING

WATER TEMPERATURE IN EXCESS OF 38° C / 100° F MAY BE INJURIOUS TO YOUR HEALTH.

WARNING

BEFORE ENTERING A SPA OR HOT TUB, MEASURE THE WATER TEMPERATURE WITH AN ACCURATE THERMOMETER.

WARNING

DO NOT USE A SPA OR HOT TUB IMMEDIATELY FOLLOWING STRENUOUS EXERCISE.

WARNING

PROLONGED IMMERSION IN A SPA OR HOT TUB MAY BE INJURIOUS TO YOUR HEALTH.

WARNING

DO NOT PERMIT ELECTRICAL APPLIANCES (SUCH AS A LIGHT, TELEPHONE, RADIO OR TELEVISION) WITHIN 1.5 METERS OF THIS SPA OR HOT TUB.

WARNING

THE USE OF ALCOHOL OR DRUGS CAN GREATLY INCREASE THE RISK OF FATAL HYPERTHERMIA IN HOT TUBS AND SPAS.

CAUTION

MAINTAIN WATER CHEMISTRY IN ACCORDANCE WITH MANUFACTURER'S INSTRUCTIONS.



Starting up your Beachcomber Hot Tub for the first time

For Hybrid Edition Hot Tubs, the external pumping and heating equipment arrives in its own separate Hybrid Equipment Box. The equipment must be hooked up to the hot tub using the separate instructions provided in the Hybrid Equipment Box. For either LEEP or Hybrid hot tubs, electrical connections must be performed by a qualified electrician. After the proper electrical connections have been performed to your proper standard codes, the qualified installer must follow these steps:

1. Check all union fittings on the Hybrid or LEEP pumping and heating equipment to ensure gaskets are in place with a tight fit. Hand-tightening is sufficient. If leaking is noted at these fittings, the gasket may be missing, not seated properly or the fitting may not be tight enough. Unscrew the union and check.
2. Open all knife valves (shown below). Fill the hot tub with water from a garden hose. You can place the hose directly in the hot tub, or attach it to the drain/fill valve located down by the pumps, to fill from the bottom. We recommended running water through the garden hose to waste for 10 seconds, before filling the hot tub to ensure fresh water from the hose source.
3. Fill the hot tub to the half way mark on the skimmer opening as shown below. For Hush Pump equipped hot tubs, the level can be lowered to one third up the skimmer opening, allowing for more displacement if the hot tub is subjected to use by more than the recommended number of people for that model. Do not allow the water to go below this level.

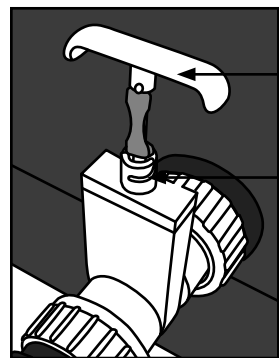

Knife Valves

Open Position: plunger is pulled upward to allow the flow of water through the pipes

Closed Position: plunger is pushed in as far as it can go, twist into the grooved lock to keep it closed.

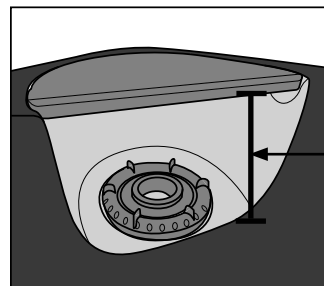

Normal water level, half way up the skimmer opening.

WARNING

OVERFILLING WITH WATER WILL NOT ALLOW ROOM FOR DISPLACEMENT FROM PEOPLE ENTERING THE HOT TUB. UNDER FILLING COULD CAUSE AN AIRLOCK IN THE SYSTEM AND COULD LEAD TO PUMP AND HEATER DAMAGE NOT COVERED BY YOUR GUARANTEE. ENSURE THE PROPER WATER LEVEL AT ALL TIMES.

WARNING

ENSURE YOUR HOT TUB IS SITUATED ON A LEVEL, HARD SURFACE CAPABLE OF SUPPORTING BOTH THE WEIGHT OF THE HOT TUB, AND THE WATER IN IT.

Placement of your Hot Tub

Beachcomber recommends that your hot tub be placed outdoors. All of our hot tubs are designed to allow you to enjoy the great outdoors, all year long. We don't recommend you place a hot tub inside your home. Beachcomber cannot be responsible for damage caused from installations; installation is your responsibility. Refer to the terms of the Guarantee in this Owner's Guide.

If you do choose to install your hot tub indoors, your qualified installer must ensure proper ventilation, floor support, service access, drainage and safety according to your local building code and safety regulations.

SIMPLICITY GIVES YOU PEACE OF MIND

We started Beachcomber in the late 70's, in a small farming community just a few miles from the USA border. It was a late, rainy evening that a small team worked hard to create the first Beachcomber Hot Tub, from that day forward we had a desire to create the finest quality products, with good, simple design in form, fit and function. That's how Beachcomber began and we still hold true to the same solid values as a family owned company today, staying focused on building a hand made quality product with a strong Guarantee.

EASY GUIDELINES TO ENSURE GUARANTEE PERFORMANCE

To receive service from an qualified Beachcomber service representative, your hot tub must be registered and you may be asked to provide an original bill of sale. Your Beachcomber Premium Guarantee starts from the original date of delivery. You may be assessed a reasonable travel cost for service at your home. It is the hot tub owner's full responsibility to provide unencumbered access to the equipment for service, removal, and/or re-installation of the hot tub for required repairs.

If Beachcomber determines that repair of the tub is not feasible it reserves the right to provide a replacement tub equal in value to the original purchased price. In this case the owner is responsible for expenses including removal, shipping and re-installation of the existing or replacement hot tub. Upon replacement of a hot tub, the Guarantee will cover the remaining portion of the existing Guarantee from the original installation date.

The Guarantee does not cover fading from natural aging and/or damage from excessive chemical use on all hot tub finishes and fixtures. Beachcomber Hot Tubs installed for commercial applications are excluded from all Guarantee coverage. The Beachcomber Premium Guarantee can not anticipate, nor does it cover, damage or failure that has occurred as a result of product abuse, accidents, power disturbances, vandalism, acts of God or nature and other causes which are out of any manufacturer's control.

All Beachcomber Hot Tubs must be used, installed and maintained as directed by the supplied Owner's Guide to receive guarantee coverage. This Beachcomber Premium Guarantee is valid only in the country of purchase. Premium Guarantee must be purchased and registered within 30 days of the original purchase.

Service after the sale is the responsibility of the dealership from whom you purchased your Beachcomber Hot Tub. All Guarantees are registered online by your Beachcomber store. Ask your store for the confirmation of your Guarantee Registration.



Keith and Judy Scott, founder of Beachcomber Hot Tubs

Confirm your Beachcomber Premium Guarantee Coverage Online

In order to confirm that your Premium Guarantee has been properly registered, you must log on to our website within 30 days of your hot tub purchase. Confirming your hot tub serial number with the Beachcomber Factory will ensure that you have the coverage that you purchased from your local store. Log on to our website, select "Customer Care => Our Guarantee" and click the Premium Guarantee link to input your serial number. If you do not see your serial number listed as being registered for the Premium Guarantee, please call our Guarantee department to confirm your coverage:

North American Customer Care: 1-800-663-6557

Beachcomber's Website: www.beachcomberhottubs.com

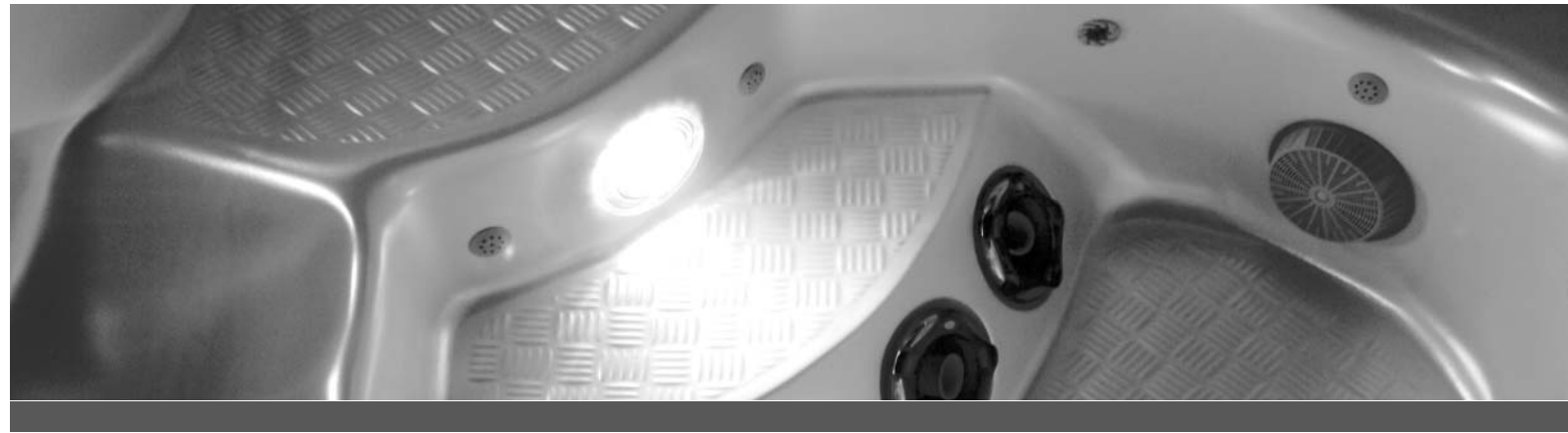

THE BEACHCOMBER PREMIUM GUARANTEE

This Guarantee is available in North America only.

Available at time of sale; see your Beachcomber store for details.

Since 1978, Beachcomber Hot Tubs has been building the finest quality hot tubs worldwide. We have taken a leadership position with our Beachcomber Guarantee that every hot tub we build is guaranteed to be free of defects. Beachcomber Hot Tubs is a family owned and operated business with hundreds of thousands of happy customers. All of our customers enjoy a worry-free, Beachcomber Certified Guarantee of Ownership, with no fine print. Your Beachcomber store will register your Guarantee online for you when you make your purchase.

LIFETIME SHELL STRUCTURAL GUARANTEE

Beachcomber guarantees to the original owner that the structural laminated fiberglass composition of your hot tub will never leak. If a failure occurs, we will supply the materials and technical labor for the repair.

5 YEAR ACRYLIC SURFACE GUARANTEE

Beachcomber guarantees that the hot tub's acrylic finish will be free from defects in materials and workmanship for five years. If a failure occurs, we will supply the materials and technical labor for the repair.

100% COMPONENT GUARANTEE

Beachcomber guarantees the following factory installed components: management system, massage pumps, Hush Pump™, motors and control panels will be free from defects in materials and workmanship for five years. If a failure occurs, we will supply the materials and technical labor for the repair.

5 YEAR ENERGY SAVER HEATER GUARANTEE

Beachcomber guarantees that the Energy Saver Heater Element Assembly will be free from defects in materials and workmanship for five years. If a failure occurs, we will supply the materials and technical labor for the repair.

5 YEAR NO LEAK PLUMBING GUARANTEE

Beachcomber guarantees against leaks caused by defects in materials and workmanship for five years. This Guarantee covers leaks from internal and external plumbing and light lenses. If a failure occurs, we will supply the materials and technical labor for the repair.

5 YEAR ENVIROSKIRT GUARANTEE

Beachcomber guarantees that the Enviroskirt cabinetry will be free from defects in materials and workmanship for five years. If a failure occurs, we will supply the materials and technical labor for the repair.

4. Open the air bleed valve to release any air trapped in the external plumbing (see equipment configuration diagrams in this guide). There is one air bleed valve on the model 321 hot tub, and all 300, 500 and 700 series hot tubs equipped with the Hush Pump.

5. With the air bled from the system, you can now turn on the power at the GFCI. Once the control panel is on, use the instructions on the following pages to complete your start up. Refer to the instructions for the control panel that matches your system.

Basic Hot Tub Configurations

Beachcomber manufactures hot tubs in two configurations; The Hybrid Edition featuring the equipment outside of the hot tub cavity under a safety step, and the LEEP Portable which features the equipment tucked inside the hot tub cabinetry behind an access door.



The LEEP Portable Hot Tub



The Hybrid Edition Hot Tub

WARNING

THE HOT TUB HEATSHIELD COVER IS STRONG ENOUGH TO WITHSTAND UP TO 2 FEET OF SNOW. IT IS NOT DESIGNED TO SUPPORT THE WEIGHT OF CHILDREN, PETS OR ADULTS. THIS EXTRA WEIGHT WILL BREAK THE FOAM INNERS AND LEAD TO PREMATURE FAILURE OF THE HEATSHIELD WHICH IS NOT COVERED UNDER THE BEACHCOMBER GUARANTEE.

MICROFILTER REMOVAL AND MAINTENANCE

The Microfilter in your hot tub should be cleaned approximately every two weeks, or more if bather load is high. Failure to clean the Microfilter can result in cloudy water, odor and potential equipment damage due to decreased water flow.

To remove the Microfilter, first put the hot tub in Standby Mode (see page 12). To remove, twist the trim ring counterclockwise to unlock it and remove along with the floating weir assembly. Lift out the basket, and pull out the Microfilter. Remove debris from the basket and rinse. Soak the Microfilter in Beachcomber's Filter Pure cleaner overnight, then rinse thoroughly with a spray nozzle to remove cleaner residue. It is recommended that you alternate Microfilter cleaning each month with Beachcomber's Filter Cure. We recommend that you have two Microfilters, to alternate while one is soaking in the cleaner. Microfilter life span is approximately two years.

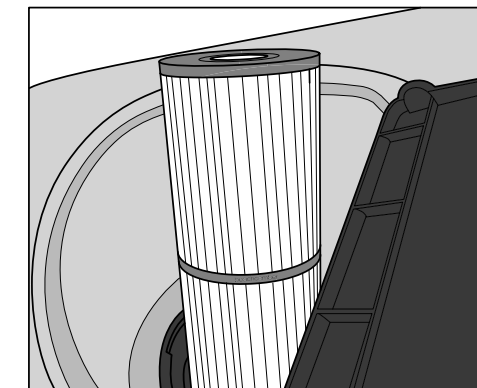

Beachcomber's Microfilter is easy to remove and replace for cleaning.

Beachcomber's Safety Features

Molded Interior Steps and Footwell Flooring

Beachcomber Hot Tubs are made with anti-slip checker plate flooring, shown below, designed to make entry and exit safer. Always use extreme caution during entry and exit, as hot tub surfaces are slippery when wet.

Body Molded Handgrips

Use the Body Molded Handgrips to prevent slipping, shown below, and to promote ease of movement while entering, soaking and exiting the hot tub.

Heatshield Cover Locks

To prevent unwanted entry by children or unauthorized users, use the cover lock assemblies, shown below, that come as a standard feature with each hot tub. Screw the female half on to the hot tub cabinet with the stainless screws provided.

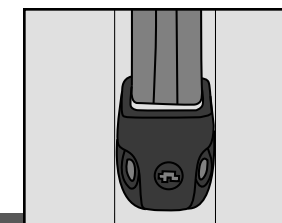

Beachcomber's Heatshield Cover Locks

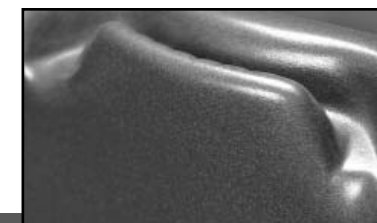

Beachcomber's Body Molded Handgrips

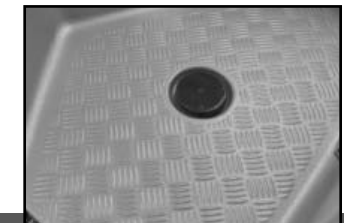

Beachcomber's Checkerplate non-slip flooring



SIMPLICITY GIVES YOU PEACE OF MIND

We started Beachcomber in the late 70's, in a small farming community just a few miles from the USA border. It was a late, rainy evening that a small team worked hard to create the first Beachcomber Hot Tub, from that day forward we had a desire to create the finest quality products, with good, simple design in form, fit and function. That's how Beachcomber began and we still hold true to the same solid values as a family owned company today, staying focused on building a hand made quality product with a strong Guarantee.

EASY GUIDELINES TO ENSURE GUARANTEE PERFORMANCE

To receive service from a qualified Beachcomber service representative, your Beachcomber Hot Tub must be registered and you may be asked to provide an original bill of sale. Your Beachcomber Guarantee starts from the original date of delivery. You may be assessed a reasonable travel cost for service at your home. It is the hot tub owner's full responsibility to provide unencumbered access to the equipment for service, removal, and/or re-installation of the hot tub for required repairs.

If Beachcomber determines that repair of the hot tub is not feasible, we reserve the right to provide a replacement hot tub equal in value to the original purchased price. In this case the owner is responsible for expenses including removal, shipping and re-installation of the existing or replacement hot tub. Upon replacement of a hot tub, the Guarantee will cover the remaining portion of the existing Guarantee from the original installation date.

The Guarantee does not cover fading from natural aging and/or damage from excessive chemical use on all hot tub finishes, fixtures and the Heatshield Cover. Beachcomber Hot Tubs installed for commercial applications are excluded from all Guarantee coverage.

The Beachcomber Guarantee can not anticipate, nor does it cover damage or failure that has occurred as a result of product abuse, accidents, power disturbances, vandalism, acts of God or nature and other causes which are out of any manufacturer's control.

All Beachcomber Hot Tubs must be used, installed and maintained as directed by the supplied Owner's Guide to receive Guarantee coverage. This Beachcomber Guarantee is valid for hot tubs sold after November 1st, 2009, only in the country of purchase. Service after the sale is the responsibility of the dealership from whom you purchased the Beachcomber Hot Tub. All Guarantees are registered online by your Beachcomber store. Ask them for confirmation of your Guarantee Registration; check our website within 30 days to confirm your registration, in the customer care section: www.beachcomberhottubs.com.

Equipment Configuration Diagrams

Please use these diagrams for component location on all Beachcomber models.

Original LEEP Portable Hot Tub, 2 Speed Pump Version

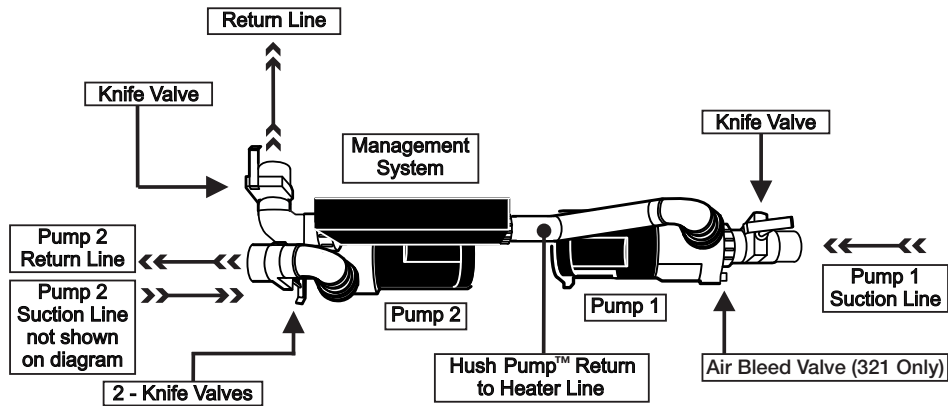

Original LEEP Portable Hot Tub, Hush Pump™ & Turbo Version

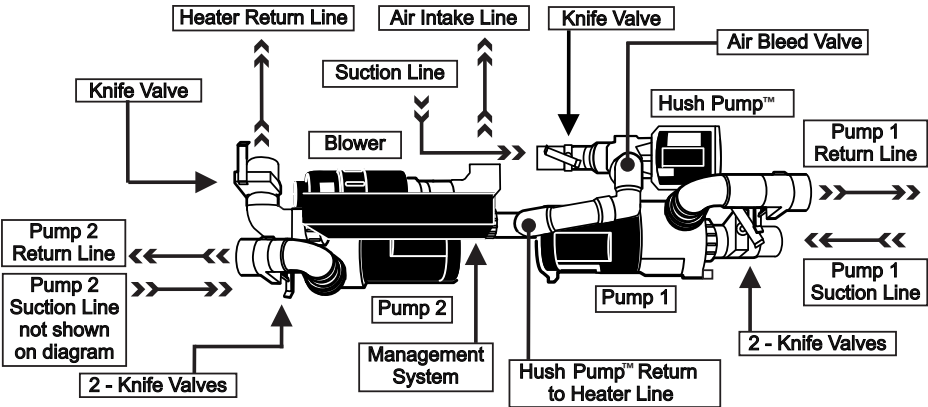

Celebrating the first Beachcomber Hot Tub in 1978.

Please Note: Your hot tub may or may not be equipped with features shown in this Owner's Guide. Beachcomber makes continual changes, upgrades and improvements; if you need more specific information on your hot tub, please call your local Beachcomber store, or use the contact information in this guide.



THE BEACHCOMBER GUARANTEE

Since 1978, Beachcomber Hot Tubs has been building the finest quality hot tubs worldwide. We have taken a leadership position with our Beachcomber Guarantee that every hot tub we build is guaranteed to be free of defects. Beachcomber Hot Tubs is a family owned and operated business with hundreds of thousands of happy customers. All of our customers enjoy a worry-free, Beachcomber Certified Guarantee of Ownership, with no fine print. Your Beachcomber store will register your Guarantee for you when you make your hot tub purchase.

LIFETIME SHELL STRUCTURAL GUARANTEE

Beachcomber guarantees to the original owner that the structural laminated fiberglass composition of your hot tub will never leak. If a failure occurs, we will supply the materials and technical labor for the repair.

5 YEAR ACRYLIC SURFACE GUARANTEE

Beachcomber guarantees that the hot tub's acrylic finish will be free from defects in materials and workmanship for five years. If a failure occurs, we will supply the materials and technical labor for the repair.

100% COMPONENT GUARANTEE

Beachcomber guarantees the following factory installed components: management system, massage pumps, Hush Pump™, motors, heater element assembly, control panels, EverLite, Eclipse Lighting, Guiding Lite, Garden EverLite, Enviro skirt Cabinetry, Ozone Generator, ClearTech UV System, Quintessential Surround Sound music system, internal and external plumbing and light lenses, will be free from defects in materials and workmanship for two years. If a failure occurs we will supply the materials and technical labor for the repair. An ozone generator uses consumable corona discharge chips that are not covered under the Guarantee. The ClearTech UV System uses consumable bulbs that are not covered under the guarantee.

100% EXCHANGE GUARANTEE

Beachcomber guarantees that the factory supplied hot tub Heatshield cover, jetting massage inserts, steps, filter baskets, Microfilter lid and remote controls will be free from defects in materials and workmanship for two years. If a failure occurs, you can exchange the failed component at your local Beachcomber store.

100% OWNER TRANSFER OPTION

The remaining portion of the Beachcomber Guarantee is transferable to a new owner for a small fee, once in the life of the Guarantee. It is the new owner's responsibility to contact a Beachcomber representative to arrange for a customer-paid installation inspection of the hot tub to activate the Guarantee transfer. The transfer fee, hot tub serial number and inspection sheet must be received by the Beachcomber Guarantee office within 60 days of ownership transfer to be valid.

Hybrid Edition Hot Tub, Hush Pump™ & Turbo Version

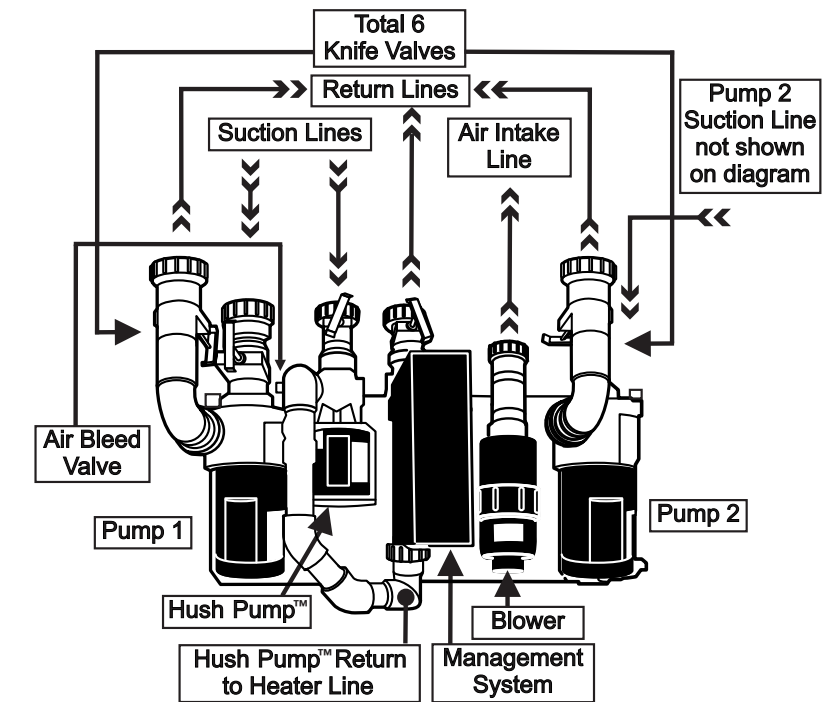

Hybrid Edition Hot Tub, 2 Speed Pump Version

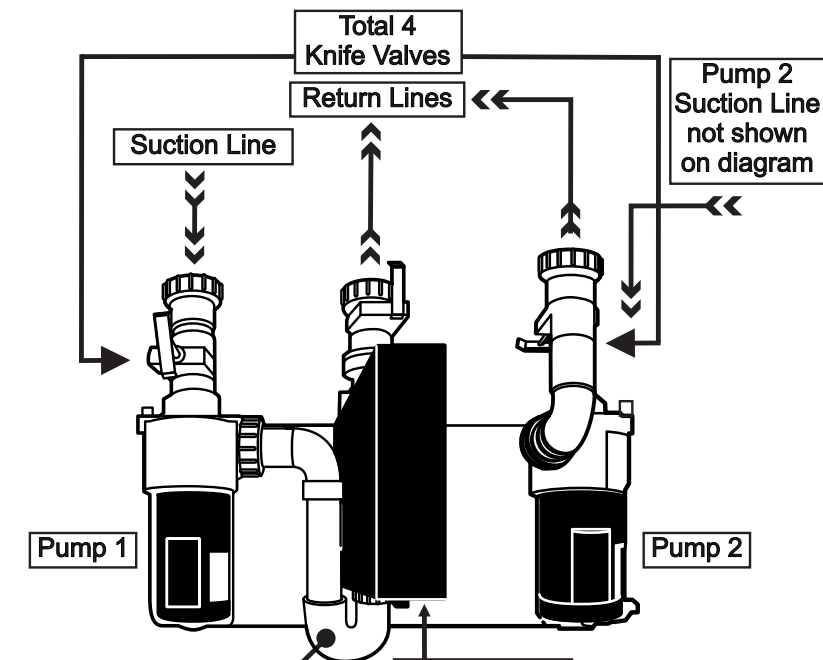

Please Note: Your hot tub may or may not be equipped with features shown in this Owner's Guide. Beachcomber makes continual changes, upgrades and improvements; if you need more specific information on your hot tub, please call your local Beachcomber store, or use the contact information in this guide.



ET-7 TOPSIDE CONTROL PANEL OPERATING INSTRUCTIONS

START UP

When your hot tub is first activated, it will go into priming mode (after displaying some configuration information). The priming mode will last up to 4 minutes; then circulation will start, then heat icon will come on for 6 seconds, and then flicker for 90 seconds. Then heater will come on to heat water to set temperature. It is recommended that priming mode be allowed to finish, preventing any pumps from operating dry. If you are positive all pumps are primed you can exit priming mode early by pressing or .

TEMPERATURE ADJUSTMENT

Temp range is: 80°F - 104°F / 26.0°C – 40.0°C The factory pre-set temperature is set at 100°F / 37.5°C. The last measured temperature is constantly displayed on the LCD. See edit menu in Owner's Guide to select F° or C°. **Note:** On non Hush Pump hot tubs, the current water temperature will only be displayed if the 2 speed filter pump has been running for two minutes.

WARM / COOL

Press the or button twice to display the set temperature. Each time either button is pressed again, the set temperature will increase or decrease depending on which button is pressed. After three seconds, the LCD will automatically display the last measured water temperature.

HEATING MODES

This button is used to switch between Standard, Economy, and Sleep modes. Press to enter mode programming, press to cycle through to desired mode (LCD flashes until confirmed), then press to confirm selection.

Standard Mode maintains the set temperature at all times. Note that the last measured hot tub temperature displayed is current only when the pump has been running for at least 2 minutes. The **STANDARD** icon will display until the mode is changed.

Economy Mode heats the hot tub to the set temperature only during filter cycles. The **ECONOMY** icon will display until mode is changed. Pressing while in Economy mode puts the hot tub in Standard-In-Economy mode, which operates the same as Standard Mode, then reverts to Economy Mode automatically after 1 hour. Use this mode to activate the heater if using the hot tub when not in filter cycle. During this time,

a press of the button will revert to Economy Mode immediately.

Sleep Mode heats the hot tub within 20°F / 11°C of the set temperature only during filter cycles. The **SLEEP** icon will display until mode is changed. Use this mode when going on holidays.

MESSAGE 1

Press button once to turn pump 1 on to low speed, press again for the pump's high speed, and once more to turn off the pump. Low speed turns off automatically after 2 hours and high speed turns off automatically after 15 minutes. Massage pump 1 comes on for a 1 minute purge at the start of each filter cycle.

MESSAGE 2

Press button once to turn pump 2 on to low speed, press again for the pump's high speed, and once more to turn off the pump. Low speed and high speed turn off automatically after 15 minutes. Massage pump 2 comes on for a 1 minute purge at the start of each filter cycle.

TURBO (optional)

Press the button to turn Turbo on and off. Turbo will automatically turn off after 15 minutes. Turbo comes on for a 10 second purge at the start of each filter cycle.

LIGHT

Press the button to turn the hot tub light on, press again to turn off. Light will automatically turn off after 3 hours.

STANDBY MODE

Pressing or followed by will turn off all hot tub functions temporarily. **SbY** will appear on your display. This is helpful when changing a Microfilter cartridge. Press any button to exit standby mode. Note: If hot tub is in a heat cycle when standby is selected the 2 speed pump or Hush Pump will run for approximately 15 seconds.

Hot Tub Operation Troubleshooting Guide, cont'd.

PROBLEM SYMPTOM	MOST LIKELY CAUSE	SOLUTION
G.F.C.I. breaker will not stay on or trips intermittently.	If hot tub is new; the load neutral wire has been inserted on the neutral buss in the panel. Load neutral wire should be inserted into the G.F.C.I. load neutral connection.	Call your Electrician to change location of the load neutral wire.
	Heater element is defective and leaking current to ground.	Call your store for service to replace the heater element.
	G.F.C.I. is worn out or defective. Class A, G.F.C.I. breakers should not trip below 5 milliamps of current leakage.	Call your electrician to replace your G.F.C.I.
Jet pump is surging on high speed.	Water level is too low on hot tubs that use a jet pump for filtering.	Raise water level in hot tub to at least ½ way up the skimmer opening.
	Plug in center of Microfilter basket is not in place on non Hush Pump equipped hot tub.	Install plug in basket, insert from top of basket.
	RFM jet nozzles are pointed toward small suction fitting in foot well.	Redirect nozzles away from the small suction fitting. Turn off all air control for RFM jets.
Neck jet does not shut off.	Internal portion of two piece neck jet has been unscrewed by turning too far to the left.	Carefully pry the faceplate off with a flat head screw driver and then thread internal back in. Then pop face plate back on and tighten internal by turning face plate clockwise.
QSS Remote control is not operating the jets and light functions from in the hot tub.	Remote batteries are low.	Replace battery.
	Remote signal booster behind eye on tub wall has a problem.	Call store for service.
QSS remote control is not operating CD player functions from in the hot tub but will operate from out of the hot tub.	Remote is not being pointed at eye on tub wall properly.	Point front of remote directly at the eye or hold closer to eye.
	Emitter on popup window has come off.	Re-attach emitter to the popup window with silicone, double-sided tape or crazy glue. Refer to CD Player manual for location of the remote eye.
Remote control does not work, CD Player functions pointing at CD player.	Batteries need replacing. Remote control is defective.	Replace batteries or see your Beachcomber store.

Diagnostic Display Messages & Trouble Shooting Guide, cont'd.

SnA or SA	Hot tub is shut down. The sensor that is plugged into the sensor "A" jack is not working.	If the problem persists, contact your store. (May appear temporarily in an overheat situation and disappear when heater cools.)
Snb or Sb	Hot tub is shut down. The sensor that is plugged into the sensor "B" jack is not working.	If the problem persists, contact your store for service.
SnS or Sn	Sensors are out of balance. If this is alternating with the temperature, it may just be a temporary condition. If the display shows only this message (periodically blinking), The hot tub is shut down.	If problem persists, contact your store for service. Follow action required for "SnA".
HFL or HL	A substantial difference between the temperature sensors was detected. This could indicate a flow problem.	Check water level in hot tub. Refill if necessary. If the water level is okay, make sure the pumps have been primed. If problem persists try these solutions: Microfilter is dirty: Turn power to tub off at GFCI or power disconnect, remove Microfilter and clean or replace. Air lock in system: Locate air bleed thumb screws and open partially to release air in piping. Debris in Hush Pump: Call your store for service or shut down system, close all knife valves and remove face plate from Hush Pump to remove debris. Circulation pump failed or frozen: If freezing suspected, place trouble light or space heater around equipment to thaw out pump and external piping and call your store for service.
LF	Persistent low flow problems. (Display on the fifth occurrence of the "HFL" message within 24 hours. Heater is shut down, but the other hot tub functions continue to operate normally.	Follow action required for the "HFL" message. Heating capacity of the hot tub will not reset automatically; you may press any button to reset.
dr	Possible inadequate water flow detected in heater after after the 3rd occurrence of dr.	Check that all knife valves are open then, check water level in hot tub. Refill if necessary. If the water level is okay, make sure the pumps have been primed. Press any button to reset.
drY or dY	Confirmed inadequate water flow detected after 7 second heater tests.	Use same action as DR. Make sure circulation pump is running. If circulating pump is not running call your store for service.
Pr	When your hot tub is first actuated, it will go into priming mode.	The Priming Mode will last up to 4 minutes and then the hot tub will begin to heat and maintain water temperature in Standard Mode.
--F / --C	Temperature unknown.	After the pump has been running for 2 minutes, the temperature will be displayed.
Std/ St STANDARD	The hot tub is operating in Standard Mode.	No action required. Refer to Heating modes page to change this mode.
Ecn/ Ec ECONOMY	The hot tub is operating in Economy mode.	No action required. Refer to Heating modes page to change this mode.
SLP/ SL SLEEP	The hot tub is operating in sleep heating mode.	No action required. Refer to Heating modes page to change this mode.

TIME OF DAY AND FILTER CYCLES SETTING

On all systems, the 2 speed filter pump or Hush Pump and ozone generator will run during filtration. There are two filter cycles per day. The start/end times of each cycle are programmable. Programming filter times on Hush Pump equipped hot tubs are used to tell the system how many hours a day to turn the heater on when in Economy mode.

To Program:

1. Press then .
2. Use the and buttons to adjust the time of day in hours, press the again to adjust the time in minutes. Use the and buttons to adjust the minutes. Press to enter new time.
3. You will see **PROGRAM, FILTER 1 (F1), START TIME** appears on the display. Press or to choose the filter start time hour. Enter the hour by pressing .
4. Press or to choose the filter start time minutes. Each press will change the start time by 5 minutes. Enter the minutes by pressing .
5. Press to see the **PROGRAM, FILTER 1 (F1), END TIME**. Adjust the time as done above.
6. Press to see the **PROGRAM, FILTER 2 (F2), START TIME**. Proceed as above.
7. Press to see **PROGRAM, FILTER 2 (F2), END TIME**. Adjust the time as done above.
8. The time that now appears allows you to turn your hot tub light on automatically. Adjust time as done above.
9. Program the time you want your light to turn off.
10. Press will enter the new filter cycle times into the system and display the current water temperature.

PANEL INVERSION

Press the or button, followed by the or button to change the numbers in the display to read upside down. Press the same sequence to set back.

LOCKING THE PANEL

Press , 1 then within 3 seconds. When locked, the **PL** indicator light will light up. All buttons are frozen except the button. To unlock the panel, press , 1 then .

LOCKING THE SET TEMPERATURE

Press or then , 1 and within 3 seconds to activate the lock. The **TL** indicator light will light up when temperature is locked. To unlock the set temperature, press or then , 1 and .

PERIODIC REMINDER MESSAGES

(press the button to reset a displayed reminder message)

rPH: Test and adjust pH chemical levels as per Beachcomber instructions. Reminder is every 7 days.

rCL: Remove, clean, and reinstall Microfilter as per Beachcomber instructions. Reminder is every 30 days.

rt9: Test & reset GFCI as per Beachcomber instructions. Reminder is every 30 days.

rdr: Drain and refill hot tub as per Beachcomber instructions. Reminder is every 90 days.

rCO: Clean and condition Heatshield as per Beachcomber instructions. Reminder is every 180 days.

rCH: Install new Microfilter. Reminder is every 365 days.

To suppress reminders, refer to the user edit menu on page 12.

DIAGNOSTIC DISPLAY MESSAGES

OHH or OHS: Overheat-DO NOT ENTER HOT TUB

ICE: Potential Freeze

SnA: Hot tub is shut down

Snb: Hot tub is shut down

SnS: Sensor out of balance

HFL: Could indicate flow problem

LF: Persistent low flow problems

dr: Inadequate water detected

drY: Inadequate water detected

Pr: Hot tub in priming mode

--: Temperature unknown

---: Temperature not current or in Economy or Sleep mode.

PLEASE REFER TO TROUBLE SHOOTING GUIDE STARTING ON PAGE 25 FOR A COMPLETE EXPLANATION OF DIAGNOSTIC MESSAGES.

WARNING

SHOCK HAZARD! NO USER SERVICEABLE PARTS.

DO NOT ATTEMPT SERVICE OF THIS CONTROL. CONTACT YOUR RETAIL STORE OR SERVICE PROVIDER FOR ASSISTANCE. FOLLOW ALL OWNER'S GUIDE POWER CONNECTION INSTRUCTIONS. INSTALLATION MUST BE PERFORMED BY A LICENSED ELECTRICIAN AND ALL GROUNDING CONNECTIONS MUST BE PROPERLY INSTALLED.

WARNING

ALWAYS TEST WATER TEMPERATURE PRIOR TO ENTRY USING THE TOPSIDE CONTROL PAD. ENSURE COMFORT BY ALSO CHECKING WATER WITH AN ACCURATE THERMOMETER.

WARNING

TAMPERING WITH OR MODIFYING THIS EQUIPMENT MAY VOID YOUR GUARANTEE.

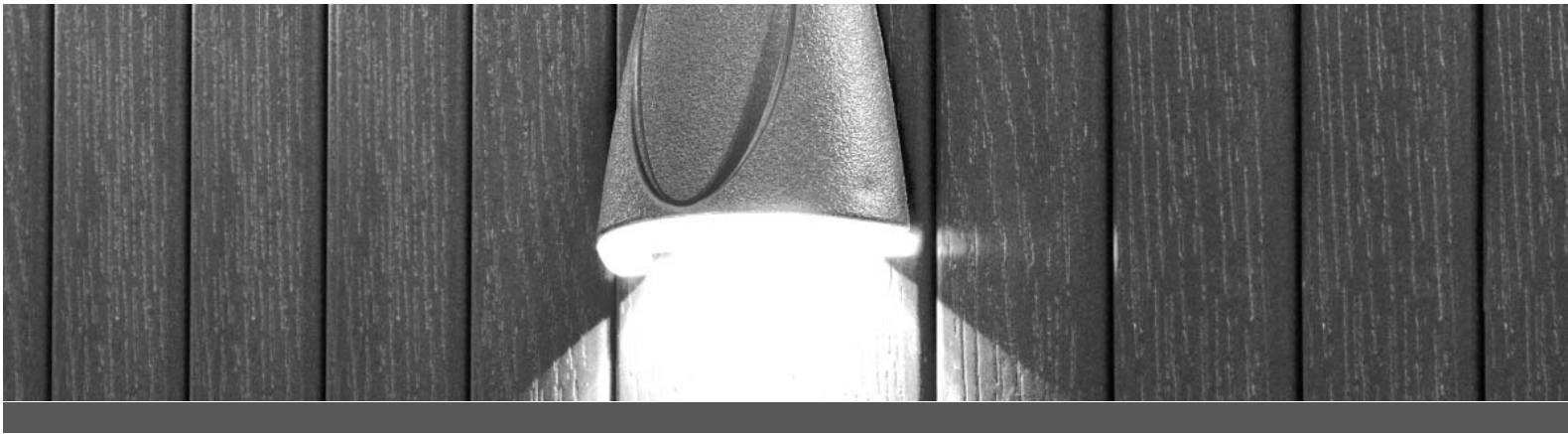

USER EDIT MENU

This feature is available on 700 Series hot tubs that have the Energy Saver Management System remote installed. There are three selections in the User Edit Menu:

- 1. Suppress Reminders:** This SST2 system will display a number of reminders prompting you to perform certain maintenance tasks. If you do not want these reminders to be displayed, you can suppress them.
- 2. Temperature Display:** You can change your temperature display from Fahrenheit to Celsius.
- 3. Time Display:** You can change the time clock display from the 12 hour am/pm to a 24 hour time clock.

ACCESSING THE USER EDIT MENU

Press the then , then , **USr** will be displayed. Then press 1 to display **Sr.n** (Suppress reminders). To suppress press 1 again to make the **n** flash. Press to change the **n** to a **Y** and then press 1 to confirm, then button twice to exit. Reminders will now be removed.

If you want to change the temp display from Fahrenheit to Celsius use the same procedure as above to get to **Sr.n** but then press to go to **tc.n** then 1 to make the **n** flash, to change the **n** to **Y** and then 1 to confirm.

If you want to change the time display from am/pm to 24 use the same procedures as above to get to **Sr.n** and then press twice to get to **24.n** then press 1 to get the **n** to flash, press to change the **n** to **Y** and then 1 to confirm then twice to exit.

Save These Instructions

Important Information

Read this important information for your safety and convenience

- 1. Read this Owner's Guide thoroughly and follow the safety guidelines provided.
- 2. If you have questions not covered in this guide, call your local store, or, in North America, call 1.800.663.6557, or (604)591-8611..
- 3. Follow water care instructions and label instructions. Failure to do so can result in damage to the hot tub or the equipment.
- 4. Always leave your Heatshield open half way when shocking your water.
- 5. Always supervise children in and around a hot tub. Do not allow children to use the hot tub unsupervised.
- 6. Test your GFCI circuit protector at least once a month to ensure it is working correctly.
- 7. Rinse your Microfilter once a week to maintain water clarity.
- 8. Always check the water temperature before entry.

- 9. Always check the sanitizer level for adequate levels. Failure to do so can cause respiratory and skin problems or disease.
- 10. Do not walk or sit on or put heavy weight on the Heatshield cover. This can cause the foam inserts to break.
- 11. Do not leave the hot tub exposed to the sun if empty. Always cover the hot tub with your Heatshield cover.
- 12. Always supervise children in and around a hot tub or pool.
- 13. Do not attempt to repair or service equipment. Consult your local Beachcomber store for expert and qualified service.
- 14. Do not attempt to drain and refill your hot tub during freezing temperatures.
- 15. Avoid using glassware in or around your hot tub.
- 16. Do not enter a hot tub if the temperature is higher than 104° F / 40° C.
- 17. Do not operate the hot tub with inadequate water level.
- 18. Do not use drugs or alcohol in or around a hot tub.

Beachcomber North American Customer Care Support
North America Toll Free 1-800-663-6557, or (604) 591-8611

Diagnostic Display Messages and Troubleshooting Guide

MESSAGE	MEANING	ACTION REQUIRED
	No message on display. Power has been shut off to hot tub. GFCI breaker is on but the control panel is blank. System fuse(s) are blown.	The control panel will be disabled until power returns. System resets time of day on each power-up. Hot tub settings are preserved. Call your store for service.
OHH or HH	"Overheat"- The hot tub has shut down. One of the sensors has detected 118°F/47.8°C at the heater.	DO NOT ENTER THE WATER. Remove the Heatshield cover and allow water to cool. Once the heater has cooled, reset by pushing any button. Check to see if the knife valve on return side of the heater is closed, if closed ensure that all knife valves are in the up or open position. If hot tub does not reset, shut off power to the hot tub and call your Beachcomber store.
OHS or OH	"Overheat"- The hot tub has shut down. One of the sensors has detected that the hot tub water is 110°F/43.3°C.	DO NOT ENTER THE WATER. Remove the hot tub Heatshield and allow water to cool. At 107°F/41.7°C. the hot tub should automatically reset. Follow action required for "OHH". If hot tub does not reset, shut off power to the hot tub and call your store.
ICE or IC	"Ice"- Potential freeze condition detected.	No action required. The Pumps and blower will automatically activate regardless of hot tub status.
SY or STBY	Hot tub is in Standby mode.	Make sure the Microfilter is back in place before pressing any button to remove from Standby.

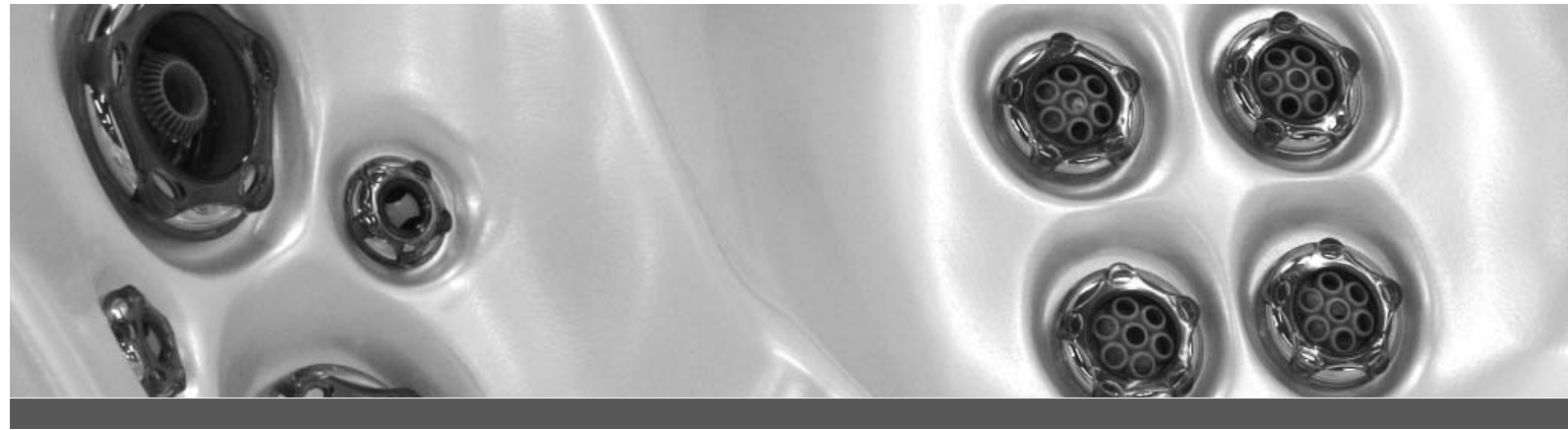

700 SERIES ET-70 TOPSIDE CONTROL PANEL OPERATING INSTRUCTIONS

Winter Operation Information

All Beachcomber Hot Tubs have built in freeze protection for their equipment. If your hot tub is not Hush Pump equipped, the freeze protection will activate the pump(s) on low speed for approximately 2 minutes if a temperature of 44° F / 7° C or below is detected at the heater housing. If your hot tub is Hush Pump equipped, the only time freeze protection will activate is if the hot tub is left in standby mode long enough to allow water at the heater to reach 44° F / 7° C or if your hot tub is filled with water that is 44° F / 7° C or lower.

There is also a small water line that runs from pump to pump that assists in protecting against freezing, by increasing circulation between the pumps.

WARNING

BEACHCOMBER HOT TUBS IS NOT RESPONSIBLE FOR NEGLIGENCE DURING FREEZING TEMPERATURES, WHICH IS BEYOND THE CONTROL OF ANY MANUFACTURER. IF POWER IS OUT DURING FREEZING TEMPERATURES, YOU MUST TAKE ACTION TO PROTECT YOUR HOT TUB AND ITS EQUIPMENT, JUST AS YOU WOULD WITH YOUR VEHICLE, OR YOUR HOME AND PROPERTY.

WINTER PRECAUTIONS

If your equipment is not working during freezing temperatures, you should first contact your local Beachcomber store or a local service provider for immediate assistance.

To prevent damage caused by the equipment freezing, place a small space heater or trouble light down by the equipment. Position the heater or light so that it does not melt or come in contact with plastic parts, to avoid equipment damage. You can also block off the step or door vent to keep in the heat during this time, but it must be removed once the freezing weather is no longer present.

EXTENDED POWER OUTAGES

In most communities, power is restored relatively quickly. But in the event of a prolonged power outage, first shut off the power at the main panel. Close the knife valves to keep the hot water in the hot tub, and remove the drain plugs or pull out one of the small braided hoses on the front of the pumps to drain all the water from the external plumbing lines and the pumps. If the power remains out for several days, you may need to remove the equipment pak to store in a warm place; call your local Beachcomber Store or service provider for assistance.

EXTENDED POWER OUTAGES... CONT'D

When power is out, check your hot tub each day to monitor its condition. DO NOT ALLOW FREEZING TO TAKE PLACE. Beachcomber Hot Tubs is not responsible for damage caused to hot tubs that are left without power in prolonged freezing conditions.

Both of Beachcomber's Hybrid and LEEP Portable configurations have equipment that is relatively easily removed. Quick Disconnect Union kits can be unscrewed to release the equipment pak, for removal to a warm place.

SHUT OFF THE MAIN POWER

Before any action in removing an equipment pak, first call your local Beachcomber Store, or service provider for assistance. If you must remove the equipment pak yourself, ensure that the main breaker is shut off at the main panel in case power is restored.

BEACHCOMBER IS NOT RESPONSIBLE FOR DAMAGE TO PERSONS OR PROPERTY FOR EQUIPMENT PAK REMOVAL. CONTACT YOUR LOCAL BEACHCOMBER STORE OR SERVICE PROVIDER FOR INFORMATION.

Shutdown Procedures

If you intend not to use your hot tub for longer than 14 days, do the following:

1. Drain the hot tub as outlined in this Owner's Guide.
2. Unscrew all union nuts on the front of the pump(s) to allow any water in the external lines to drain out. Retain the gaskets found at these locations, along with the equipment.
3. Locate and remove the small black slotted drain plugs found on the front of the pump(s) below the union nuts from step 2. or remove the small braided hose from the barbed fitting on the front of the Hush Pump. Removing these allows the last bit of water in the bottom half of the pump to drain out.
4. Remove the Microfilter cartridge and store in a dry place.
5. Lock Heatshield and attach Hurricane strapping if in high wind areas.
6. Provide extra support for the Heatshield if in extreme heavy snow by placing a 4 x 8 sheet of 3/4" plywood on top of the Heatshield.

BEACHCOMBER HOT TUBS IS NOT RESPONSIBLE FOR DAMAGE TO HOT TUBS THAT ARE LEFT UNATTENDED.

START UP

Before turning on the power make sure you have read the Start Up instructions on page 6. When your hot tub power is first turned on it will display a series of numbers identifying the software version and the voltage input. It will then go into a 4 minute priming mode indicated by a **Pr** on the LCD display. During priming mode the Hush Pump will circulate the water through the filter and heating system to allow the temperature to be read. If your tub is not Hush Pump equipped the jet pump will not turn on until the prime mode times out or the button is pressed to time out early. During prime mode the jet pumps can be turned on to make sure they are fully primed and moving water in the tub. Do not allow an unprimed jet pump to run for more than 10 seconds. If the fill water temperature is below 44° F / 7° C freeze protection will activate all pumps immediately. While the circulation pump is running the display will show a -- °F indicating current temperature is not known. This will take two minutes. Once temperature is known it will be displayed on the LCD.

TEMPERATURE ADJUSTMENT

The temperature range is 80°F - 104°F / 26°C – 40°C. The default is 100°F/37.5°C. Any temp changes are saved in the system memory if power is interrupted. Use the button to increase and the button to lower the set points. After showing set temp the LCD will revert back to current water temp.

Note: if set temp is lowered more than 3°F / 1.5°C below current water temp the Hush Pump™ will stop. The circulation will restart every 30 minutes to check if water temp has come down to set temp. It will also run continually during programmed times.

HEATING MODES

Std – Standard Mode: (Default mode) In Standard Mode the water is always heated to the set temperature. The display will show the current temperature and the word **STANDARD**.

Ecn – Economy Mode: In Economy Mode the water is heated only during the filter cycle times. Default times are 8:00 am to 10:00 am for cycle 1 and 8:00 pm to 10:00 pm for cycle 2. If using economy you may need to alter these times to make sure the

water is at your desired temp during your usual tub use times. The display will alternate between **Ecn** and the current temperature and display the word **ECONOMY**.

SLP – Sleep Mode: In Sleep Mode the water is only heated to within 20°F / 11°C of your set point and the heater only comes on during the programmed filter cycle times. This mode is typically only used for vacation time. The display will alternate between the current temperature and **SLP**.

To change heating modes press the button then the button.

MESSAGE 1

To activate this jet pump press the 1 button once to activate low speed, The icon will flash off and on, on the LCD display. Press again to activate high speed and the icon will become solid on the display. Press a third time to turn the pump off. The low speed will turn off automatically after 4 hours and the high speed will turn off after 15 minutes.

Note: If the hot tub is Hush Pump equipped, the low speed of Message 1 will come on automatically for 1 minute at the start of each filter cycle to purge the plumbing lines. If the purge time is not at the time of day you want, change the filter times.

MESSAGE 2

To activate this jet pump press the 2 button once to activate low speed, The icon will flash off and on, on the LCD display. Press again to activate high speed and the icon will become solid on the display. Press a third time to turn the pump off. The low speed and the high speed will turn off automatically after 15 minutes.

Note: If the hot tub is Hush Pump equipped, the low speed of Message 2 will come on automatically for 1 minute at the start of each filter cycle to purge the plumbing lines. If the purge time is not at the time of day you want, change the filter times.

LIGHT

To activate, press the button once to turn on and again to turn off. The light will automatically turn off after 4 hours. If your tub has an EverLite 6 or any additional







lighting features see the instructions in this Owner's Guide.

TURBO (OPTIONAL)

To activate, press the  button once to turn on and again to turn off. The Turbo will turn off automatically after 15 minutes. The Turbo will come on automatically for 30 seconds at the start of each filter cycle to purge the Turbo plumbing. If the purge time is not at the time of day you want change the filter times.

SETTING TIME CLOCK AND FILTER CYCLES







Time Set

To set the time clock to your local current time press the  button, then the  button and Set Time appears. Press the  button to advance the time or the  button to back up the time. The time will advance quickly 5 seconds after pressing the  or  buttons. Use the same button to stop the clock at the desired time.

Filter Cycle Setting

Filter cycles come preset from the factory. For hot tubs without the Hush option, filter cycles are default to run two hours each time, twice a day. For hot tubs with the Hush option, filter cycles are default to 24 hours.

Filter cycle duration and frequency are adjustable and can be changed by following the instructions below.

Once time of day is set press the  button to set start time of Filter cycle 1. If your hot tub is Hush Pump equipped, changing filter cycles does not affect the time the pump runs. It tells the system when to turn on the heater if you are using the Economy heat setting. If your tub is non Hush Pump, changing the cycle time tells the two - speed pump 1 when to operate for a filter cycle. Avoid programming a long filter cycle that runs during the day time hours in hot summer weather as it could cause the water to overheat. Use the  or  buttons to advance or backup the Filter 1 start time. Press the same button to stop the time once you reach the desired start time. Press the  button to advance to the Filter 1 stop time and use the same procedure as above to adjust. Press the  again to select Filter 2 start time then use the same procedure as above to adjust, then press  to select Filter 2 stop time and once set, press  to exit the menu.

Make sure you do not program the cycles to overlap the start or stop time of either

TOPSIDE CONTROL PANEL STANDBY FEATURE







The Standby feature is used primarily to temporarily shut the circulation pump off before removing the Microfilter for cleaning or replacement. This prevents debris or objects from entering the circulation pump while the skimmer basket and filter are out. Standby can also be used if you want to have total quiet while using the hot tub; however, during this time the hot tub will not heat. Use the instructions below to put your hot tub into Standby. Please note: Do not use Standby to drain and refill your hot tub. Always shut off power at the main breaker before draining your hot tub to prevent damage to the hot tub equipment.

Press  then  to put the tub into Standby; display will show **stby**. Press any button to take the hot tub out of standby.







cycle.

Any changes to filter cycles and time are stored in the system memory and will be retained in the event of a power outage.



PANEL LOCK

This feature might be used if you do not want anyone to operate the tub in your absence. To lock the panel press, , then  then  within three seconds. A pad lock icon will appear on the LCD. To unlock press , then , then  within three seconds.

TEMPERATURE LOCK

This feature might be used to prevent other tub users such as children from adjusting the tub set temperature. To lock the set temperature press, , then  then  1 then  within 3 seconds. To unlock press , then  1 then  within 3 seconds.

DIAGNOSTIC DISPLAY MESSAGES

	Power to Hot Tub is off
	Current temperature not known
OHH	Possible overheated heater: do not enter Hot Tub
OHS	Possible overheated Hot Tub: do not enter Hot Tub
SnA	Sensor problem
Snb	Sensor problem
SnS	Sensors out of balance
HFL	Possible flow through heater problem
LF	Confirmed flow through heater problem
dr	Possible dry heater problem
drY	Confirmed dry heater problem
ICE	Freeze condition sensed

Refer to diagnostic and trouble shooting section starting on page 25 for additional detailed information.

WARNING

SHOCK HAZARD! NO USER SERVICEABLE PARTS.

DO NOT ATTEMPT SERVICE OF THIS CONTROL. CONTACT YOUR RETAIL STORE OR SERVICE PROVIDER FOR ASSISTANCE. FOLLOW ALL OWNER'S GUIDE POWER CONNECTION INSTRUCTIONS. INSTALLATION MUST BE PERFORMED BY A LICENSED ELECTRICIAN AND ALL GROUNDING CONNECTIONS MUST BE PROPERLY INSTALLED.

WARNING

TAMPERING WITH OR MODIFYING THIS EQUIPMENT MAY VOID YOUR GUARANTEE.

WARNING

ALWAYS TEST WATER TEMPERATURE PRIOR TO ENTRY USING THE TOPSIDE CONTROL PAD. ENSURE COMFORT BY ALSO CHECKING WATER WITH AN ACCURATE THERMOMETER.

CLEARTECH UV WATER CARE SYSTEM (OPTIONAL)

Your hot tub may be equipped with ClearTech. This unit uses a specialized ultra violet light bulb which produces UV light. Bacteria are destroyed as the water passes through the tube and under this light. The UV bulb is rated at 15,000 hours. The glass sleeve covering the bulb should be inspected and cleaned (if necessary) at each drain and fill. For service or replacement, consult your Beachcomber store.

HUSH PUMP™

The Hush Pump is a very quiet, low amperage, high flow circulation and filtration pump that looks after the filter and heating functions of your hot tub. It comes set from the factory to operate 24 hours a day.

Draining Your Beachcomber Hot Tub

Change three to four times a year or more if bather load is high. To calculate the change frequency, use the following formula:

$$\# \text{ DAYS} = \frac{1}{3} (\text{VOLUME IN US GALLONS})$$

MAX # OF DAILY BATHERS

Before draining, check the sanitizer level. It should not be above 1.0 ppm, to ensure no harm is done to the surrounding environment. If sanitizer level is high, use Beachcomber's **Neutr-All** as directed on the label.

1. Turn power off at the G.F.C.I. breaker or power disconnect switch (do not use the standby feature).
2. Locate the black drain/fill valve shown below, found inside behind the door on a Portable LEEP model or under the step on the Hybrid Edition. Remove the safety cap from the fitting threaded into the valve.
3. Attach the female end of your garden hose and place the other end at a level lower than the drain/fill valve to ensure complete draining. To open, turn the outer part of the drain/fill valve counter clockwise to open and start the draining.
4. Draining time will vary from model to model.
5. Once the hot tub is drained and empty, disconnect the garden hose and close the valve if you are not going to fill the hot tub through the valve. If you want to fill through this valve, unscrew the threaded adapter and thread in the male end of a garden hose, then attach the female end to your tap and refill.

Vacation Instructions

If you are leaving your hot tub full and running while on vacation for 3-5 days, do the following:

1. Check and adjust pH level if necessary.
2. Shock-treat the water to raise the sanitizer level. Leave the hot tub Heatshield half open for 1 hour.
3. Lower the water temperature to the minimum setting (optional).
4. Lock your Heatshield on the hot tub to maintain a safe environment for pets or children. If you are in a high wind area, install Hurricane Straps (available from your local Beachcomber store) to secure the Heatshield to your hot tub.

Upon returning do the following:

1. Check pH and sanitizer level and adjust if necessary.

If leaving for 5-14 days and no one can come by to maintain the hot tub, do the following:

1. Lower the set temperature to 80° F / 26.5° C. Sanitizers may last longer in cooler water.
2. Check and adjust pH and Total Alkalinity level if necessary.
3. Use either a Beachcomber floating tablet dispenser or a Holiday Tender tablet dispenser to automatically dispense either **Bromine Disc** or **Mini Disc** in your hot tub water to maintain water disinfection. Use the low setting on these devices as the demand for disinfectant will be low during this time.
4. Lock the Heatshield and attach a Hurricane Strap in high wind areas.

Upon returning do the following:

1. Check pH and sanitizer level and adjust if necessary.
2. Return temperature setting to your desired level.

WARNING

ENSURE AN UNATTENDED HOT TUB HAS A SECURED AND LOCKED HEATSHIELD COVER TO PREVENT UNWANTED ENTRY. BEACHCOMBER HOT TUBS IS NOT RESPONSIBLE FOR DAMAGE CAUSED TO PROPERTY OR PERSON BY HOT TUBS THAT ARE LEFT UNATTENDED FOR PERIODS OF TIME.

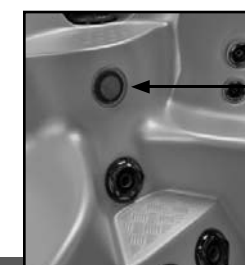

Hot tub light

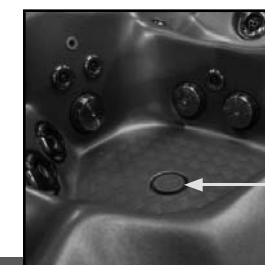

Gravity Floor Drain for easy draining



Drain / Fill Valve



Hush Pump



QUINTESSENTIAL SURROUND SOUND SYSTEM™

To operate the optional Quintessential Surround Sound System shown below, lift up the front cover located on the outside of the Enviroskirt Cabinet and insert a CD or select a radio station, select volume between 28-34. If you purchased the optional remote, refer to the remote control reference card for operation instructions. The remote is water resistant but not meant to be left in the water for storage. If you have the optional QSS Plus System, the CD player fader control should be left in the zero position. Complete instructions are available in the CD Player owners manual included with your hot tub.

HOT TUB UNDERWATER LIGHTING

All Beachcomber Hot Tubs come standard with either a 12 volt incandescent light or a digital EverLite™ LED light. Your local Beachcomber store is best equipped to replace either unit. Drain the hot tub and locate the lens removal tool included with the hot tub. Carefully unscrew the light lens. Carefully pull out the light unit and replace with a new one, available from your local Beachcomber store. Screw the lens back in until tight, but do not over tighten.

WATERFALL

Hot tubs equipped with the optional Waterfall feature shown above, will have a topside control valve to increase or decrease the water flow to the Waterfall. The Waterfall feature receives its flow from the Hush Pump or 2 speed circulation pump. If your hot tub is equipped with the Eclipse Lighting Feature, the Waterfall will also be backlit. The control valve must be left open when the hot tub is not in use.

TURBO

The optional Turbo shown below increases the amount of air turbulence that comes out of the jets. It enhances massage pressure, turbulence and water action. With the Turbo activated and air controls are closed, air from the Turbo will come out of the 4 salt shaker relief jets found in the foot well of the hot tub. It is your choice to use the air controls or not.

OZONE

Your hot tub may be factory equipped with an optional Ozonator unit, or factory pre-plumbed to accept the installation of an Ozonator.

Ozonators produce a powerful gas, and injects it into the hot tub water to oxidize organic contaminants in the water and improve water clarity. Please note: an Ozonator is not designed to replace your main sanitizer / disinfectant system.

The Ozonator is equipped with a small viewing window. When ozone gas is produced, a purple glow is best seen at night in this window. This diminishes over time as they chip wears out. When no purple glow is seen during filtration cycles (not heating cycles), this is an indication that the chip requires replacement. The chip is rated at 9000 hours (one year).

WARNING

NO USER SERVICEABLE PARTS. DO NOT ATTEMPT TO SERVICE AN OZONATOR OR CLEARTECH UV UNIT OR ANY OTHER PART OF YOUR BEACHCOMBER HOT TUB EQUIPMENT PAK. CONTACT YOUR LOCAL STORE FOR SERVICE AND/OR REPLACEMENT. DO NOT VIEW THE UV BULB IN OPERATION. UV RAYS CAN CAUSE IRRITATION AND/OR BLINDNESS.

WARNING

THE USE OF AN OZONATOR OR CLEARTECH UV UNIT IS NOT A REPLACEMENT FOR A WATER SANITIZING PROGRAM. FAILURE TO PROPERLY SANITIZE HOT TUB WATER CAN CAUSE IRRITATION AND/OR DISEASE.

500 SERIES ET-55 TOPSIDE CONTROL PANEL OPERATING INSTRUCTIONS

STARTUP

Before turning on the power, make sure you have read the Start Up instructions on page 6. When your hot tub power is first turned on it will display a series of numbers identifying the software version and the voltage input. It will then go into a 4 minute priming mode indicated by a **Pr** on the LCD display. During priming mode the Hush Pump will circulate the water through the filter and heating system to allow the temperature to be read. If your hot tub is not Hush Pump equipped, the jet pump will not turn on until the prime mode times out or the **Temp** button is pressed to time out early. During prime mode the jet pump can be turned on to make sure they are fully primed and moving water in the hot tub. Do not allow an unprimed jet pump to run for more than 10 seconds. If the fill water temperature is below 44°F / 7°C freeze protection will activate all pumps immediately. While the circulation pump is running the display will show a - - indicating current temperature is not known. This will take two minutes. Once temperature is known it will be displayed on the LCD.

TEMPERATURE ADJUSTMENT

The temperature range is 80°F - 104°F / 26.0°C – 40.0°C. The default is 100°F/37.5°C. Any temp changes are saved in the system memory if power is interrupted. Press the **Temp** button to increase or lower the set points. If the **Temp** is pressed the set point will flash. Each press will move the set point 1 degree. If the set point is moving the wrong direction then stop pressing, let the temperature display stop flashing, then press again to move the set point in the other direction. After adjusting the set temp, the LCD will revert back to the current water temperature.

Note: if set temp is lowered more than 3°F / 1.5°C below current water temp, the Hush Pump will stop. The circulation will restart every 30 minutes to check if water temp has come down to set temp. It will also run continually during programmed times.

HEATING MODES

St – Standard Mode (Default Mode) In Standard Mode the water is always heated to the set temperature. The display will show the temperature always with Hush Pump equipped systems. If non Hush Pump, current water temperature will be shown when the pump is running and when pump is not running. If your hot tub is not equipped with

a Hush Pump, the 2 speed pump will come on every 30 minutes outside of filter cycles to poll for current water temperature. If you do not want this to happen, use the Economy mode below.

Ec – Economy Mode: In Economy Mode the water is heated only during the filter cycle times. The factory default is F4 (4 hours), 2C (twice a day). If using the Economy mode, you may need to alter these times to make sure the water is your desired temperature during your usual hot tub usage times. The first filter cycle starts 6 minutes after power is turned on. The display will alternate between the current temperature and **Ec**.

SL – Sleep Mode: In Sleep Mode the water is only heated to within 20°F / 11°C of your set point and the heater only comes on during the programmed filter cycle times. This mode is typically only used for vacation time. The display will alternate between the current temperature and **SL**.

To change heating modes, press the **Temp** button then the **Temp** button.

MASSAGE

To activate this jet pump, press the **Massage** button once to activate low speed, twice to activate high speed and three times to turn the pump off. The low speed will turn off automatically after 4 hours and the high speed will turn off after 15 minutes. If the hot tub is Hush Pump equipped, the low speed of the jet pump will come on automatically for 1 minute at the start of each filter cycle to purge the plumbing lines.

LIGHT

To activate this press the **Light** button once to turn on and again to turn off. The light will automatically turn off after 4 hours. If your tub has an EverLite 6 or any additional lighting features see the instructions on page 20 of this manual.

TURBO (OPTIONAL)

To activate this press the **Turbo** button once to turn on and twice to turn off. The Turbo will turn off automatically after 15 minutes. The Turbo will come on automatically for 30 seconds at the start of each filter cycle to purge the Turbo plumbing.

SETTING FILTER CYCLES

Filter cycles come preset from the factory. For hot tubs without the Hush option, filter

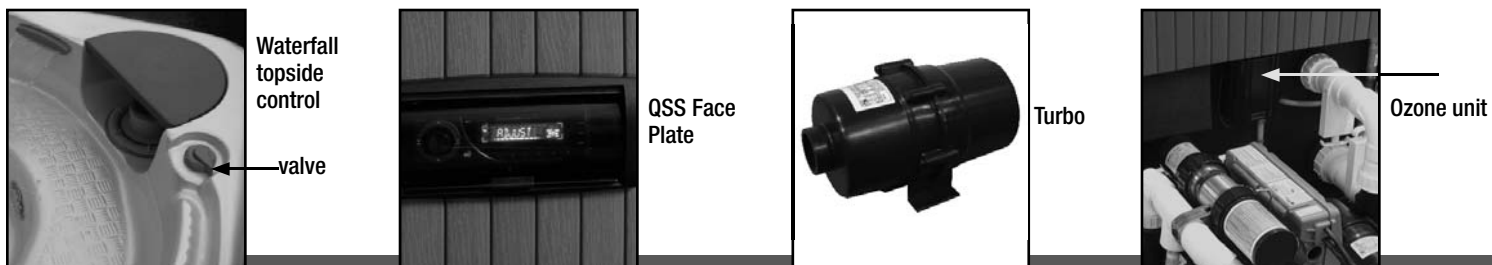

cycles are default to run two hours each time, twice a day. For hot tubs with the Hush option, filter cycles are default to 24 hours.

Filter cycle duration and frequency are adjustable and can be changed by following the instructions below.

Press the **⏏** then press **⏏** to bring up F2 keep pressing **⏏** to select F4, F6, F8, FC (12 hours). Then press **⏏** to bring up 2C (two cycles per day). If you want to change press **⏏** to select 1d (day cycle) and again to select 1n (night cycle). Press **⏏** to exit programming.

DIAGNOSTIC DISPLAY MESSAGES

○	Power to Hot Tub is off
--	Current temperature not known
HH	Possible overheated heater: do not enter Hot Tub
HS	Possible overheated Hot Tub: do not enter Hot Tub
SA	Sensor problem
Sb	Sensor problem
Sn	Sensors out of balance
HL	Possible flow through heater problem
LF	Confirmed flow through heater problem
dr	Possible dry heater problem
dY	Confirmed dry heater problem
IC	Freeze condition sensed

Refer to diagnostic and trouble shooting section starting on page 25 for additional detailed information.

TOPSIDE CONTROL PANEL STANDBY FEATURE

The Standby feature is used primarily to temporarily shut the circulation pump off before removing the Microfilter for cleaning or replacement. This prevents debris or objects from entering the circulation pump while the skimmer basket and filter are out. Standby can also be used if you want to have total quiet while using the hot tub; however, during this time the hot tub will not heat. Use the instructions below to put your hot tub into Standby. Please note: Do not use Standby to drain and refill your hot tub. Always shut off power at the main breaker before draining your hot tub to prevent damage to the hot tub equipment.

Press **⏏** then **✖** to put the hot tub into Standby. Display will show **SY**. Press any button to take the hot tub out of standby. **Note:** For ET-7 standby instructions, See page 10.

WARNING

SHOCK HAZARD! NO USER SERVICEABLE PARTS.

DO NOT ATTEMPT SERVICE OF THIS CONTROL. CONTACT YOUR RETAIL STORE OR SERVICE PROVIDER FOR ASSISTANCE. FOLLOW ALL OWNER'S GUIDE POWER CONNECTION INSTRUCTIONS. INSTALLATION MUST BE PERFORMED BY A LICENSED ELECTRICIAN AND ALL GROUNDING CONNECTIONS MUST BE PROPERLY INSTALLED.

WARNING

TAMPERING WITH OR MODIFYING THIS EQUIPMENT MAY VOID YOUR GUARANTEE.

WARNING

ALWAYS TEST WATER TEMPERATURE PRIOR TO ENTRY USING THE TOPSIDE CONTROL PAD. ENSURE COMFORT BY ALSO CHECKING WATER WITH AN ACCURATE THERMOMETER.

PLASTIC COMPONENTS

The jets should be removed periodically and rinsed out to remove debris from the spinning assemblies. If calcium build-up is present, soak the parts in Filter Cure to loosen the calcium and then scrub with a brush and rinse off. Debris on suction covers (located in the foot well) can reduce water flow to the pumps. Ensure that suction covers remain clean and unobstructed.

Operation of Hot Tub Interior Features

FLEXJET INSERTS

The jets in a Beachcomber Hot Tub are known as Energy-Jets™ and are available in four sizes; small, medium, large and extra large. They are interchangeable within the same sizes. Simply turn them counter-clockwise to unscrew. To reinstall, turn the jet insert clockwise to screw them back in. The jets can also be individually turned off or on by turning the jet face. Turning it clockwise will turn off the water flow and counter-clockwise turns on the water flow.

To turn on the neck jet, twist the jet face counter-clockwise; to turn off, twist it clockwise. If this jet does not turn off then carefully pry the face plate off with a flat head screw driver, and screw the internal portion back in by hand. Then pop the face plate back on and turn it clockwise to tighten in the internal portion.

REFLEX FOOT MASSAGE (RFM) DIVERTER VALVE

This top side valve shown below diverts water flow between either the RFM foot jets or the seat jets.

On 700 series hot tubs it diverts water flow from massage 2 pump between the RFM foot jets or the seat jets on the left side of the hot tub.

Always turn the pump to low speed or off before attempting to turn the RFM Diverter Valve. Failure to do this could cause the handle to break due to the high velocity of

water moving through the valve.

Note: When the hot tub is not being used, the diverter valve handle must be left in the center position. This ensures that water in both zones is always in circulation during periods of non use.

AIR CONTROL VALVES

There are two air control valves located on either side of the touch pad, as shown below. These air controls improve the massage experience in your hot tub by adding more turbulence to the water flow. To turn on the air, turn the knob counter-clockwise.

300, and 500 series hot tubs The left air control services the seat jets on the left of the hot tub and jets in the foot well. The right air control services the seat jets on the right side of the hot tub. If equipped with the Reflex Foot Massage (RFM) option, the right air control services the RFM jets when the water flow is diverted to them, and the left air control services all the seat jets.

700 series hot tubs The left air control allows air flow to jets running off Massage Pump 1. The right air control allows air flow to jets running off Massage Pump 2. The right air control would also allow air flow to the RFM jets if the diverter valve is diverting water flow from Massage Pump 2 to the RFM jets.

On all models, more air is drawn in when the jet pump is on high speed than when the pump is on low speed.

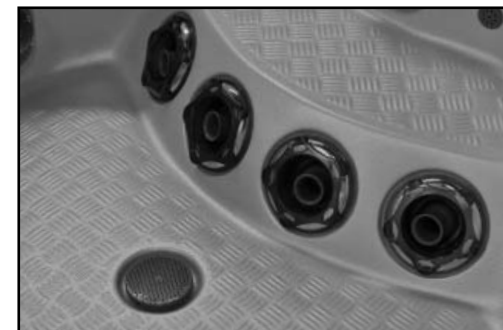

Beachcomber's Reflex Foot Massage Jets (RFM - 700 Series shown)



Beachcomber's Reflex Foot Massage Diverter Valve (RFM)

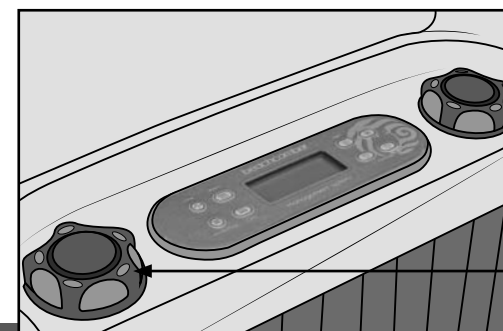

Beachcomber's Air Control Valves, situated on each side of the control pad.

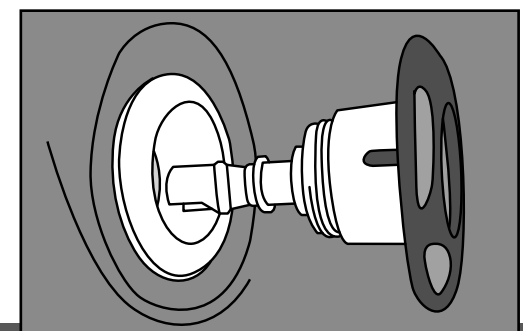

Beachcomber's Jets are interchangeable within the same size range.

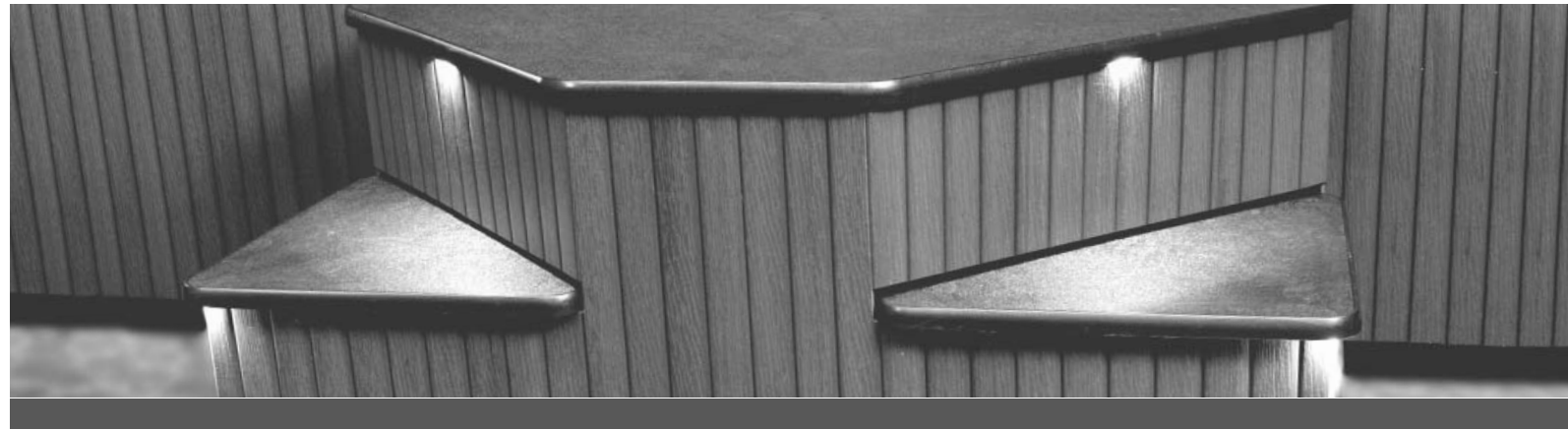

EverLite™ Operating Instructions

Note: Points 1 through 4 apply to the EverLite 4. The EverLite 6 includes all six of the following points.

- 1. Beachcomber Mode A** - Light will sequence from Red, to Green, to Blue continuously. Press the light button once to start the **'Beachcomber Mode A'**. Light will stay on each solid color for three seconds. The color will blend with the next color for four seconds before the next color becomes a solid. To turn off, press button once. *
- 2. Freeze Mode** - As it cycles through the 'Beachcomber Mode A', the light can be frozen on any solid or blended color. Choose a color, and then touch the button twice (off, then on) within four seconds to switch to **'Freeze Mode'**. To turn off, press button once.
- 3. Pulse Mode** - This is a random cycling mode, which imitates the soothing rhythm of a heartbeat. When in the **'Freeze Mode'**, touch the button twice (off, then on) within four seconds to switch to **'Pulse Mode'**. To turn off, press button once.
- 4. White Mode** - This mode recreates natural white light. When in the **'Pulse Mode'**, touch the button twice (off, then on) within four seconds to switch to **'White Mode'**. To turn off, press button once.

ZONED MODE (PROGRAMMABLE)

- 5. Beachcomber Mode B** - All lights above waterline, (including Eclipse Lighting, and Waterfall Light), are turned on, while all underwater lights are off. When in the **'White Mode'**, touch the button twice (off, then on) within four seconds to switch to **'Beachcomber Mode B'**. To turn off, press button once.

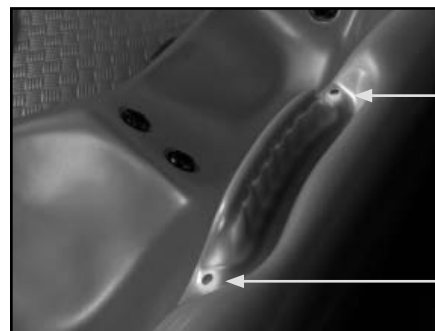

Beachcomber's Eclipse Mood Lighting optional feature

- 6. Beachcomber Mode C** - All lights below waterline are turned on, while all lights above water, (including Eclipse Lighting, and Waterfall Light), are off. When in the **'Beachcomber Mode B'**, touch the button twice (off, then on) within four seconds to switch to **'Beachcomber Mode C'**. To turn off, press button once.

*Note: If the light is left off for more than ten seconds, it will revert back to 'Beachcomber Mode A' when switched back on.

Hot Tub Care and Maintenance

CLEANING OF THE ACRYLIC SURFACE

The acrylic surface is very easy to maintain and care for. Use **Tub Clean** to remove water level scum lines with warm water and a damp cloth; wipe down, avoiding contact with the water as Tub Clean can cause foaming.

HEATSHIELD COVER

As with any vinyl product that is exposed to the weather, the better the care, the longer it will last. Use a mild dish soap solution to remove dirt on the Heatshield and then treat the vinyl by applying **Cover All** as per the label. Avoid application in the hot sun.

HOT TUB CABINETRY AND STEPS

The cabinet and step of your hot tub is made from a synthetic plastic called Enviroskirt. If the cabinet is dirty, simply wipe it down with a soft cloth and a mild soap solution, and rinse well.

WARNING

DO NOT USE A CLEANER THAT CONTAINS AMMONIA. THIS COULD DAMAGE YOUR ACRYLIC SURFACE. DO NOT LEAVE THE HOT TUB EMPTY WITH THE ACRYLIC SURFACE EXPOSED TO THE HOT SUN. ALWAYS PUT THE HEATSHIELD BACK ON THE HOT TUB WHEN IT IS NOT IN USE.

WARNING



DO NOT USE AN ABRASIVE CLEANER TO CLEAN THE ENVIROSKIRT™ CABINET AS THIS WILL DAMAGE THE FINISH.

300 SERIES ET-50 TOPSIDE CONTROL PANEL OPERATING INSTRUCTIONS

STARTUP

Before turning on the power, make sure you have read the Start Up instructions on page 6. When your hot tub power is first turned on it will display a series of numbers identifying the software version and the voltage input. It will then go into a 4 minute priming mode indicated by a **Pr** on the LCD display. During priming mode the Hush Pump will circulate the water through the filter and heating system to allow the temperature to be read. If your hot tub is not Hush Pump equipped, the jet pump will not turn on until the prime mode times out or the  button is pressed to time out early. During prime mode the jet pump can be turned on to make sure they are fully primed and moving water in the hot tub. Do not allow an unprimed jet pump to run for more than 10 seconds. If the fill water temperature is below 44°F / 7°C freeze protection will activate all pumps immediately. While the circulation pump is running the display will show a - - indicating current temperature is not known. This will take two minutes. Once temperature is known it will be displayed on the LCD.

TEMPERATURE ADJUSTMENT

The temperature range is 80°F - 104°F / 26°C - 40°C. The default is 100°F / 37.5°C. Any temp changes are saved in the system memory if power is interrupted. Press the  button to increase or lower the set points. If the  is pressed the set point will flash. Each press will move the set point 1 degree. If the set point is moving the wrong direction then stop pressing, let the temperature display stop flashing, then press again to move the set point in the other direction. After adjusting the set temp, the LCD will revert back to the current water temperature.

Note: if set temp is lowered more than 3°F / 1.5°C below current water temp, the Hush Pump will stop. The circulation will restart every 30 minutes to check if water temp has come down to set temp. It will also run continually during programmed times.

HEATING MODES

St – Standard Mode (Default Mode) In Standard Mode the water is always heated to the set temperature. The display will show the temperature always with Hush Pump equipped systems. If non Hush Pump, current water temperature will be shown when the pump is running and – when pump is not running. If your hot tub is not equipped with a

Hush Pump, the 2 speed pump will come on every 30 minutes outside of filter cycles to poll for current water temperature. If you do not want this to happen, use the Economy mode below.

Ec – Economy Mode: In Economy Mode the water is heated only during the filter cycle times. The factory default is F4 (4 hours), 2C (twice a day). If using the Economy mode, you may need to alter these times to make sure the water is your desired temperature during your usual hot tub usage times. The first filter cycle starts 6 minutes after power is turned on. The display will alternate between the current temperature and **Ec**.

SL – Sleep Mode: In Sleep Mode the water is only heated to within 20°F / 11°C of your set point and the heater only comes on during the programmed filter cycle times. This mode is typically only used for vacation time. The display will alternate between the current temperature and **SL**.

To change heating modes, press the  button then the  button.

MASSAGE

To activate this jet pump, press the  button once to activate low speed, twice to activate high speed and three times to turn the pump off. The low speed will turn off automatically after 4 hours and the high speed will turn off after 15 minutes. If the hot tub is Hush Pump equipped, the low speed of the jet pump will come on automatically for 1 minute at the start of each filter cycle to purge the plumbing lines.

LIGHT

To activate this press the  button once to turn on and again to turn off. The light will automatically turn off after 4 hours. If your tub has an EverLite 6 or any additional lighting features see the instructions on page 20 of this manual.

TURBO (OPTIONAL)

To activate this press the  button once to turn on and twice to turn off. The Turbo will turn off automatically after 15 minutes. The Turbo will come on automatically for 30 seconds at the start of each filter cycle to purge the Turbo plumbing.

SETTING FILTER CYCLES

Filter cycles come preset from the factory. For hot tubs without the Hush option,

filter cycles are default to run two hours each time, twice a day. For hot tubs with the Hush option, filter cycles are default to 24 hours.

Filter cycle duration and frequency are adjustable and can be changed by following the instructions below.

Press the **⏏** then press **⏏** to bring up F2 keep pressing **⏏** to select F4, F6, F8, FC (12 hours). Then press **⏏** to bring up 2C (two cycles per day). If you want to change press **⏏** to select 1d (day cycle) and again to select 1n (night cycle). Press **⏏** to exit programming.

DIAGNOSTIC DISPLAY MESSAGES

○	Power to Hot Tub is off
--	Current temperature not known
HH	Possible overheated heater: do not enter Hot Tub
HS	Possible overheated Hot Tub: do not enter Hot Tub
SA	Sensor problem
Sb	Sensor problem
Sn	Sensors out of balance
HL	Possible flow through heater problem
LF	Confirmed flow through heater problem
dr	Possible dry heater problem
dY	Confirmed dry heater problem
IC	Freeze condition sensed

Refer to diagnostic and trouble shooting section starting on page 25 for additional detailed information.

TOPSIDE CONTROL PANEL STANDBY FEATURE

The Standby feature is used primarily to temporarily shut the circulation pump off before removing the Microfilter for cleaning or replacement. This prevents debris or objects from entering the circulation pump while the skimmer basket and filter are out. Standby can also be used if you want to have total quiet while using the hot tub; however, during this time the hot tub will not heat. Use the instructions below to put your hot tub into Standby. Please note: Do not use Standby to drain and refill your hot tub. Always shut off power at the main breaker before draining your hot tub to prevent damage to the hot tub equipment.

Press **⏏** then **✖** to put the tub into Standby. Display will show **SY**. Press any button to take the hot tub out of standby.

WARNING

SHOCK HAZARD! NO USER SERVICEABLE PARTS.

DO NOT ATTEMPT SERVICE OF THIS CONTROL. CONTACT YOUR RETAIL STORE OR SERVICE PROVIDER FOR ASSISTANCE. FOLLOW ALL OWNER'S GUIDE POWER CONNECTION INSTRUCTIONS. INSTALLATION MUST BE PERFORMED BY A LICENSED ELECTRICIAN AND ALL GROUNDING CONNECTIONS MUST BE PROPERLY INSTALLED.

WARNING

TAMPERING WITH OR MODIFYING THIS EQUIPMENT MAY VOID YOUR GUARANTEE.

WARNING

ALWAYS TEST WATER TEMPERATURE PRIOR TO ENTRY USING THE TOPSIDE CONTROL PAD. ENSURE COMFORT BY ALSO CHECKING WATER WITH AN ACCURATE THERMOMETER.

EverLite "4" Operating Instructions

1. Beachcomber Mode - *The light will sequence from Red, to Green, to Blue continuously.*

Press the light button once to start the 'Beachcomber Mode'. The light will stay on each solid color for three seconds. The color will blend with the next color for four seconds before the next color becomes a solid. To turn off, press the button once. *

2. Freeze Mode - *As it cycles through the 'Beachcomber Mode', the light can be frozen on any solid or blended color.* Choose a color, and then touch the button twice (off, then on) within four seconds to switch to 'Freeze Mode'. To turn off, press the button once.

3. Pulse Mode - *This is a random cycling mode, which imitates the soothing rhythm of a heartbeat.* When in the 'Freeze Mode', touch the button twice (off, then on) within four seconds to switch to 'Pulse Mode'. To turn off, press the button once.

4. White Mode - *This mode recreates natural white light.* When in the 'Pulse Mode', touch the button twice (off, then on) within four seconds to switch to 'White Mode'. To turn off, press the button once.

**Note: If the light is left off for more than ten seconds, it will revert back to 'Beachcomber Mode' when switched back on.*



EverLite "6" Operating Instructions

1. Beachcomber Mode A - *The light will sequence from Red, to Green, to Blue continuously.*

Press the light button once to start the 'Beachcomber Mode A'. The light will stay on each solid color for three seconds. The color will blend with the next color for four seconds before the next color becomes a solid. To turn off, press the button once. *

2. Freeze Mode - *As it cycles through the 'Beachcomber Mode A', the light can be frozen on any solid or blended color.* Choose a color, and then touch the button twice (off, then on) within four seconds to switch to 'Freeze Mode'. To turn off, press button once.

3. Pulse Mode - *This is a random cycling mode, which imitates the soothing rhythm of a heartbeat.* When in the 'Freeze Mode', touch the button twice (off, then on) within four seconds to switch to 'Pulse Mode'. To turn off, press button once.

4. White Mode - *This mode recreates natural white light.* When in the 'Pulse Mode', touch the button twice (off, then on) within four seconds to switch to 'White Mode'. To turn off, press button once.

5. Beachcomber Mode B - *All lights above waterline are turned on, while all underwater lights are off.* When in the 'White Mode', touch the button twice (off, then on) within four seconds to switch to 'Beachcomber Mode B'. To turn off, press the button once.

6. Beachcomber Mode C - *All the lights below the waterline are turned on, while all the lights above the water line are off.* When in the 'Beachcomber Mode B', touch the button twice (off, then on) within four seconds to switch to 'Beachcomber Mode C'. To turn off, press the button once.

**Note: If the light is left off for more than ten seconds, it will revert back to 'Beachcomber Mode A' when switched back on.*

ZONED MODES